

Solutions

Affordable IBS Homes



PRIMA Solution : Affordable Industrialised Building System (IBS) Homes or in other words prefabricated homes, generally offers a better solution compared to the conventional construction houses. Often become the choice for affordable homes projects (i.e; Program Projek Perumahan Rakyat Termiskin (PPRT), Community Development of 'Kampung Orang Asli', Tadika KEMAS & many more).

Introduction

Industrialised Building System (IBS)

Industrialised building system (IBS) is a term used in Malaysia, (commonly known as “Pre-fabrication” construction in the other parts of the world) referring to a technique of construction whereby components are manufactured in a controlled environment, either on site or off site, placed and assembled into construction works.

The implementation of IBS minimizes many technical glitches and limitations that are constrained within the conventional in-situ building method. The advantages of IBS include faster construction time, cost savings, less man hours for construction, less room for errors and etc.

The Malaysian Government had piloted many programs and promotions to encourage the adoption of IBS by builders, contractors as well as developers over the years. The government understands the urgency and need to ensure that the construction industry is not restraining from the technological advancement of construction methods used by the forward-thinking nations worldwide.



Fibre Cement Boards/ Solution: The New Norm

Fibre cement board is the an innovative and ideal building materials that are ideal building materials that are commonly used in the construction of Industrialized Building System (IBS). Fibre cement board covers the exterior and interior applications of a building in both residential and commercial properties.

Acceptance of IBS is on the uptrend as the system is noted to be more versatile, consistent and significantly require less time to implement and with greatly reduced activities at the construction site which in turn provides cost savings to the builders.

In other words, the IBS is created and designed based on the current socio-economic condition in mind, giving all stakeholders the flexibilities to construct their desired shelters as a whole.

The IBS is widely adapted in most of the developed countries like Australia, US, UK and Japan as the technology behind it is deemed to be more sustainable, making it a superior alternative when being equated to conventional construction. Common bits and pieces that are looked into involves criteria such as; time savings, cost-effectiveness, consistencies, durability, logistics and the ability for mass production.



IBS houses overseas



IBS houses overseas

Features and Benefits

- Cost effective
- Fast & easy construction
- Lightweight
- Good quality & fire safe material
- Structurally calculated & endorsed
- Durable
- Green label material
- Flexible design & suitability
- Minimum on-site workers required
- Material ease of delivery
- Better project cash flow

PRIMA by Saint-Gobain Prima Sdn Bhd

Saint-Gobain Prima Sdn Bhd is a global player in the manufacturing of high quality fibre cement boards. With state of the art technology and strict controls, Saint-Gobain Prima is proud to brand its products as PRIMA boards. PRIMA boards are made available in different categories and can be used for many different applications and areas.

Standards & Certifications

PRIMA Solutions: IBS Homes main materials meets the national & international industry standards namely; MS1296:2010, BS476: Part 6 & 7, CIBD PPS (Bahan Binaan), BOMBA (Class O), SIRIM ECO-LABEL, ISO 9001, ISO 14001, ISO 8336:2009, ISO 2383:2013, MS1196:2006, MS 2382:2011, ISO 8384:2011, ISO 2385:2011, JIS G 3302:2010 and JIS G 3312:2012.

On the design parameter, compliance to local building codes may apply where relevant as advised by the project consultant(s).



Winning design of the International Design Competition for the Tropical House for Orang Asli Exhibition organized by Kuala Lumpur Architecture Festival 2019 for the Semi Urban and Rural Categories which were constructed using PRIMA boards.

Total Solution for Affordable Homes Project

Taking into considerations that many builders are constantly looking forward to innovations and ideas, we are now offering a solution based guide in building homes that focuses on affordability, sturdiness and safety. Construction time required would be just a fraction of the conventional methods.

PRIMA Affordable IBS Homes Solution emphasizes the usage of materials with proper specifications and construction methodology, in a holistic manner.

As such, any house design or layout from architects or designer, can be used as a start and fused with PRIMA Affordable IBS Homes Solution. The system will include the super-structure and architectural design of the building.

PRIMA Affordable IBS Homes Solution will be of great help to the architects and engineers when it comes to establishing the desired layout with input from the home or project owners. Upon confirmation, the building structure can now be fabricated in the factory and subsequently be delivered to the site for assembly and construction.

Applications

PRIMA Affordable IBS Homes Solution can be used as a pre-construction platform when it comes to building individual houses, residential housing, community facilities, plantation quarters, orchard facilities, army quarters, disaster relief homes, charity buildings, religious buildings and many more. Initiatives such as Program Perumahan Rakyat Termiskin (PPRT) and Tabika KEMAS by the Ministry of Rural Development (KPLB) are among the projects that have benefited from the PRIMA Affordable IBS Homes Solution.

PRIMA KampungKu

Constructed with up to 90% of PRIMA Boards



Scan to Watch
PRIMA KampungKu
construction
time lapse

Tabika Kemas Desa Harapan Tapah, Perak, Malaysia

Kindergarten in Kg. Kinjang, Chenderiang, Tapah.
Constructed with up to 90% of PRIMA Boards



A pioneer program initiated by the Ministry of Rural Development (Kementerian Pembangunan Luar Bandar)

Construction duration: 20 days from ground zero
Size: 660 ft²

Officiated by: YB Datuk Seri Rina bt Mohd Harun
Menteri Pembangunan Luar Bandar 2018-2020
and
YAB Dato Seri Ahmad Faizal bin Azumu
Menteri Besar Perak 2018-2020



Scan to Watch
Tabika Kemas Tapah
Desa Harapan
construction
time lapse

Completed projects using PRIMA Affordable IBS Homes Solution



PPRT Kampung Dugang, Tuaran, Sabah, Malaysia

Size : 660 ft²

Consist of 3 bedrooms, living room, dining area, kitchen, 1 bathroom and 1 toilet



PPRT Kampung Ibol, Sri Aman, Sarawak, Malaysia

Size : 660 ft²

Consist of 3 bedrooms, living room, dining area, kitchen, 1 bathroom and 1 toilet



Rumah Hijau, Tongod, Sabah, Malaysia

Size : 870 ft²

Consist of 3 bedrooms, living room, dining area, kitchen, 2 bathrooms, verendah and yard



The Village Resort, Mesilao, Kundasang, Sabah, Malaysia

Size : 500 ft²

Consist of 2 bedrooms, living room, dining area, kitchen, 1 bathrooms and verendah



Rumah Bantuan Mangsa Banjir, Tanah Merah, Kelantan, Malaysia

Size : 820 ft²

Consist of 3 bedrooms, living room, dining area, kitchen, 1 bathroom and 1 toilet



Tabung Haji Plantation Staff Quaters, Pusa, Sarawak, Malaysia

Size : 810 ft²

Consist of 3 bedrooms, living room, dining area, kitchen, 1 bathroom, 1 toilet and 1 porch

Components of PRIMA Solution : Affordable IBS Homes

The New Construction Technology

PRIMA Solutions: IBS Homes was developed specifically to overcome the limitations and drawbacks of conventional construction methods such as inconsistent workmanship, delays and unnecessary variation in orders can be effectively minimized.

Components of PRIMA Solution IBS Homes

- 1) Substructure (Foundation)
- 2) Superstructure
- 3) Architectural

1) Substructure (Foundation)

Option 1: Reinforced Concrete Sub-Structure (In-situ)

- Lightweight super structure allows less loading foundation design.
- Advantages: less excavation, less cost, less formwork, distribute the load over a large area, resists differential settlement & suitable to a certain degree of poor soil condition.
- R.C raft foundation design (by others) for conventional on the ground house is subjected to soil conditions.
- Alternative to other cast in-situ types of foundations. (i.e.: pad, piling, strip foundation & etc.)

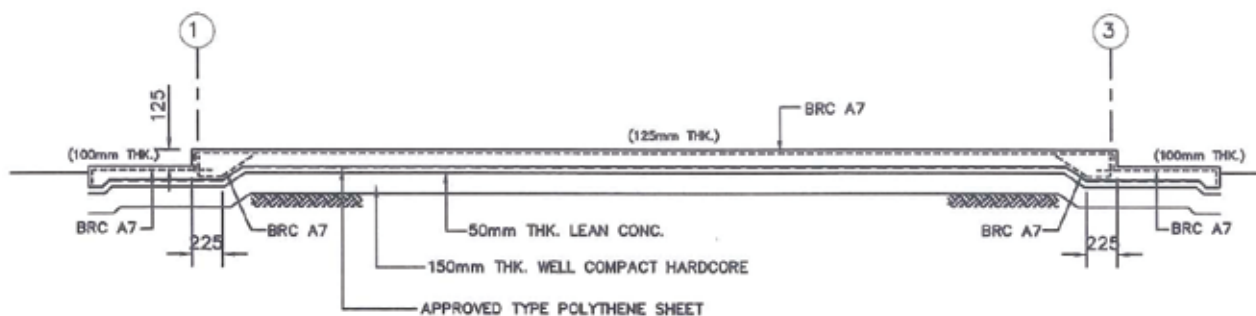

**Example of foundation.*

**For illustration purpose only. Subject to qualified Engineer's design and endorsement.*



R.C raft foundation design for conventional on ground house

Option 2: IBS Proprietary Anchorage System

- IBS Proprietary Anchor or equivalent foundation system is suitable for the elevated house design.
- Fast and easy to construct.
- Adjustable stilt height.
- Tri-pod concept of soil anchoring.
- Suitable to most soil condition. Professional consultation required.
- Excellent in sloping topography site or hilly site.
- Recommended the use of light weight Steel Bearer and Joist for flooring structure to Professional Engineer's design and details.



Tri-pod concept of soil anchoring

IBS Proprietary Anchorage System



IBS Proprietary Anchorage System for elevated house

2) Superstructure (Walls and Roof Frames)

- Uses high quality Light Gauge Steel (LGS) Framing.
- Eliminates conventional columns, beams, stiffeners and lintels.
- Load bearing structural design engineered using special software.
- Includes design parameters of dead, live, lateral loads and up to seismic structural design (optional).
- Cold Form Steel Coils folded into 'C' and 'U' shape profiles.
- Steel thicknesses ranging from 0.75mm to 1.20mm.
- Corrosion protection from alloy coating.
- Comes with pre-punched section for electrical and plumbing services inside the walls.
- Components prefabricated to form wall panels in the factory.
- Installed on R.C slab (on the ground) or Mild Steel frames (elevated) prepared earlier at the site.
- Includes roof structure.

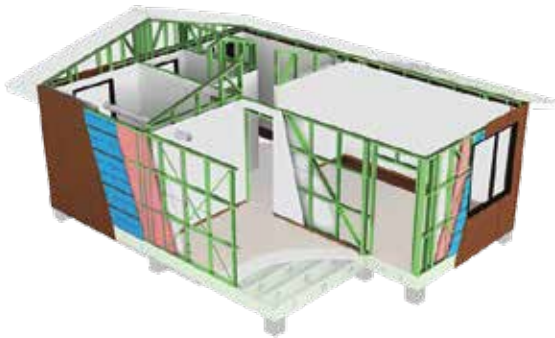

LGS Frames Structure



LGS Framing Machine



LGS Frame

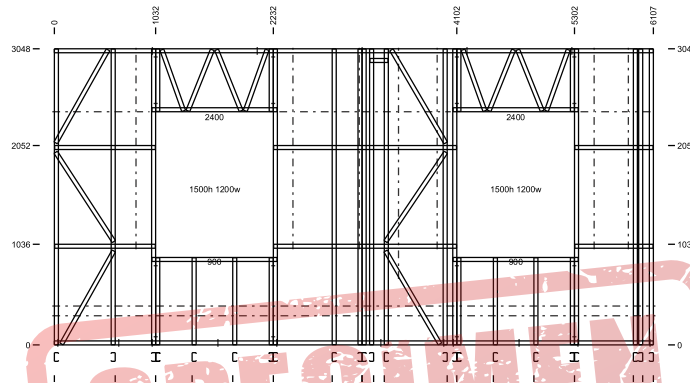

<<< Joins L1

Quantity Required = 1 Mark as L2 Header Engineering = Passed

Joins L3 >>>

LOADS & DESIGN FACTORS		SPECIAL LOADING		FASTENERS		BRACING	
WIND FACTORS Terrain Factor 1.00 Shikling Factor 1.00 Topography Factor 1.00		No Point Load Applied		Connection Type: Stud to Plate Fastener Name: FRAMECAD 10g-19mm XDrive Number: 2 (one each side)		Inplane: Provide Nogs and Solid Bracing as shown Out-of-Plane: Provide Restraint at Top and Bottom of Panel Additional Stud Restraint Height: None	
DESIGN LOADING Case Type Load Unit G Gravity(Dead) 0.71 kN/m Cr Roof Live 0.56 kN/m Cf Floor Live Load 0.00 kN/m P Concentrated Live 1.1 kN Wu Wind Up 1.64 kN/m Wd Wind Down 1.03 kN/m Wh Wind Horizontal 0.66 kPa Sw Self Weight 0.34 kN/m		JAMB STUD ACTIONS Location StudQty Vertical (kN) Lateral (kN) mm Down Up/Lift Down Up/Lift 4102 1 2.02 -1.15 0 0 5302 1 0.72 -0.10 0 0 1032 1 0.77 -0.16 0 0 2232 1 1.91 -1.09 0 0		Web to Plate & Head Minimum: FRAMECAD 10g-19mm XDrive Additional: FRAMECAD 10g-16mm Flathead Jack Stud to jamb: FRAMECAD 10g-19mm XDrive		kx 0.8 Lx Height 0.8 Ly Nog 1.0 Lt Nog *Height* denotes nominal panel height *Nog* denotes maximum spacing	
Stud Stud Material: 89S41-075-500 Stud Spacing Type: Single Absolute Nominal Wall Height: 3006.0mm Nominal Noggin Spacing: 1036.0mm Max Nominal Stud Spacing: 1425.0mm Actual Nominal Stud Spacing: 600.0mm Stud Engineering Compliance: 42% Maximum Base Reactions: 2.29 (Down) kN/m, 0.69 (Up) kN/m				OPENING DESIGN Note 1 - Jamb Screws: (S) denotes Sill, (H) denotes Head. Code Location Type Lintel/Beam Additional Screws Jamb Screws Header Sill Head Warning 1500h 1200w 4102 Webbed Head None 0 2(S)(H) Passed No design No design 1500h 1200w 1032 Webbed Head None 0 2(S)(H) Passed No design No design		BASE FIXING Note: The results here come from the Databse Use L1 to check the floor type under the Loading Information section. Panel/Usage Type: Load Bearing Panel Base(Floor) type: Concrete Minimum: TITAN THD10X80 @ 0mm centres Panel Ends: TITAN THD10X80 & 50mm Flat Washer Jamb Stud: TITAN THD10X80 & FRAMECAD Hold Down Fix	
Results for Uniform Loads Stud Material: 89S41-075-500 Stud Spacing Type: Single Absolute Nominal Wall Height: 3006.0mm Nominal Noggin Spacing: 1036.0mm Max Nominal Stud Spacing: 1425.0mm Actual Nominal Stud Spacing: 600.0mm Stud Engineering Compliance: 42% Maximum Base Reactions: 2.29 (Down) kN/m, 0.69 (Up) kN/m				WALL NOTE Top Plate designed to support detailed joist or truss only. Plate or Floor system to be specified by Engineer to distributed loads from walls above to stud Base Plate not designed for vertical loads Structural support to provided under each stud. Wall and Header are not designed for concentrated loads in Structural Wall			
Framing System Name: Wall Type: Load Bearing		Panel RL (mm) : Envelope: 3048h 6107w		Direction: Zone: Not Used		Loading Code: Steel Design Code: AS/NZS 1170:2002 AS/NZS 4600:2005	
						Design Wind speed: Wall Location: W35 External	

Specimen extracted from design software for illustrative purposes only.

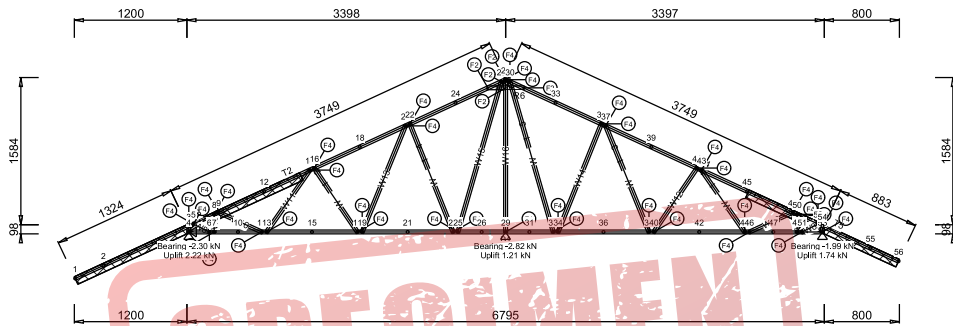

Quantity Required = 3 Mark as T2 Engineering Status = Passed
 Minimum number of fasteners required is 3 per joint

LOADS & DESIGN FACTORS	DESIGN LOADING	FASTENERS	BRACING	MAXIMUM MEMBER AXIAL FORCES AND CRITICAL STRUCTURAL DESIGN INDEX	
WIND Factors Terrain Factor 1.00 Shielding Factor 1.00 Topography Factor 1.00 SNOW Factors No Snow Load Apply Wind Pressure Factors Wup Bottom Chord 0.2 Top Chord 0.9 Wdown Bottom Chord 0.3 Top Chord 0.2	Load Cases: Type G Gravily(Dead) Q Roof Live P Concentrated Live S Snow Wu Wind Up Wd Wind Down	Fixing Type: Name City Main Fixing: FRAMECAD 10g-19mm XDrive 2 Sub Fixing: FRAMECAD 10g-16mm Flathead Refor DWG Reinforced: Gave Fixing: FRAMECAD 10g-19mm XDrive Drawing F# denotes total number of fasteners required at joint. Provide plate or reinforcing member where number of screw in a flange exceeds 2, or where screw spacing requirement can not be met. Min Screws Spacing: 3 x Diameter. Min Edge Distance: 2.2d for End Edge, or 1.5d for Side Edge.	Provide Chord Restraints: at specified spacing Roof System Bracing: to be Specified by Engineer Member Effective Lengths for Design Type Kx Lx Ky Ly Kt Lt Chords 0.75 Panel 1.00 Rest. 0.75 Min(Lx,Ly) Web 1.0 Panel 1.0 Panel 1.0 Panel * Panel 'denotes distance between panel points * Rest. 'denotes lateral restraint spacing	(All member actions are factored as per specified load combination) Top Chord Member Com. Ten. CSI LC 29-32 -0.78 0.67 23% (16) 32-38 -0.37 0.52 45% (16) 38-44 -0.34 1.19 44% (17) 44-49 -1.55 2.11 28% (18) 49-53 -1.55 2.10 10% (18) 14-20 -1.23 0.89 56% (21) 20-27 -0.35 0.89 66% (22) 27-30 -0.28 1.23 14% (16) Member Com. Ten. CSI LC 30-35 -0.44 0.92 66% (23) kN kN 35-41 -1.12 1.14 56% (24) -6 -3.81 2.39 23% (19) 41-48 -1.80 1.16 85% (25) 7-11 -1.58 2.77 10% (6) 48-52 -2.36 1.12 31% (26) 13-17 -1.31 0.83 8% (19) 52-56 -0.67 0.78 36% (28) 18-23 -1.35 1.33 9% (21) 25-29 -2.71 1.70 28% (4) 30-35 -1.38 1.74 10% (6) 37-41 -0.91 1.39 6% (25) Bottom Chord Member Com. Ten. CSI LC 43-48 -0.84 1.51 5% (25) 48-52 -1.74 2.35 11% (26) 4-6 -1.14 1.18 18% (19) 43-54 -1.90 1.73 6% (26) 6-11 -3.37 2.18 26% (11) 11-17 -0.84 1.54 44% (12) 17-23 -0.72 1.20 45% (13) 23-29 -0.77 0.68 23% (13)	
SPECIAL LOADING No Point Load Applied	DESIGN LOAD COMBINATIONS LC1 (0.4G+Wu) 32% LC2 (G) 14% LC3 max(1.0G,0.7S) 24% LC4 (1.2G+1.5Q) 29% LC5 (1.2G+Wd) 37% LC6 (0.9G+Wu) 46% LC7 (0.9G+Ww) 19% LC8 (0.9G+Wl) 18% LC9 (1.2G+Ww) 26% LC10 (1.2G+Wl) 26% LC11-LC26 (1.2G+1.5P) 85%	DEFLECTION LC Max Node Criteria Critical CSI mm ID mm mm LC1 4.25 1 Span180,20.0 13.5 31.6% LC2 1.09 1 Span300,20.0 8.1 13.5% LC3 1.98 1 Span300,20.0 8.1 24.2%	REINFORCING PLATES & MEMBERS		
Framing System Name: Loading Code: Design Code:	AS/NZS 1170:2002 AS/NZS 4600:2005	Top Chord Restraint (mm) : 900 Horizontal Chord Restraint (mm) : N/A Bottom Chord Restraint (mm) : 600	Truss Spacing (mm) : 1069 Add. supported Area (m²) : 0.0 Shuttered Conditions: No	Roof Load Type: SHEET Ground Snow Load (kPa): 0.00 Design Wind speed: W35	Bottom Chord Dead Load (kPa): 0.12 Bottom Chord Live Load (kPa): 0.00 Bottom Chord Service Load (kPa): 0.00 Top Chord Dead Load (kPa): 0.12 Top Chord Live Load (kPa): 0.25 Concentrated Live Load (kN) : 1.10

Specimen extracted from design software for illustrative purposes only.

Special Features

- Lightweight structure give less loading to foundation or substructure.
- Flexible to be used for any house design.
- Fast and easy to install on-site.
- Requires less on-site equipment, machinery and transportation.
- Easy handling thus requiring less manpower.
- Structurally stable & strong.
- Durable material.
- All dry construction.
- Flexible to accommodate any roof finishes (roof tiles / metal / slates / shingles).
- Possible for house extension (renovation).

Benefits & Advantages of Light Gauge Steel (LGS) Framing

1. Lightweight and Durable

Produced using state of the art machinery, light gauge steels are made in a stringent manufacturing environment whereby the tolerance for straightness is close to 100%, making them extremely heavy-duty and sturdy when used correctly. In this instance, chances of damage during construction or failure while in transit are nearly impossible. LGS weights only at a fraction of normal steel due to the technological advancements of its design and characteristics. When compared, normal steels are typically very heavy and are mainly used in large-scale construction projects. The strength of LGS allows it to be used when the larger spacing between framing sections are required, which in turn reduces cost and man hours. In terms of logistic and installation, LGS is easy to transport and provides much more flexibilities in panel combinations during constructions.

2. Strength

LGS has a high strength-to-weight ratio and is strong enough to support a large load whilst being lighter than timber and concrete. It's light enough to reduce the load of foundations and be easily transported – this allows for modular construction in a factory environment. The physical properties of the LGS are what makes it the ideal choice for medium to low rise commercial and residential buildings.

3. Dimensional stability

Given the strength and durability of steel, it won't be easily distorted or fail under imposed load. It's also non-combustible, as opposed to its timber. The dimensional stability is what makes LGS the perfect fit for home construction.

4. Speedy construction

The lightweight nature of LGS allows for off-site modular construction, leading to a more accurate result and less call-backs. Modular construction is also not affected by weather, ultimately reducing the amount of delays during the construction period. On average, modular construction can ensure projects are completed up to 20% * faster than on-site construction methods.

5. Environmentally-friendly

The accuracy and timeliness of manufacturing and construction of LGS components can help in reducing materials wastage significantly, making it environmentally friendly. Since steels are termite-proof and do not attract pests, chemical treatments are usually not required. All these factors lead to a more sustainable ecosystem and form an all win situation for both mankind and mother nature.

*Source: "Cost Benefit Analysis For Industrialised Building System (IBS) Industry in Malaysia", by CIDB Malaysia and CREAM (The Construction Research Institute of Malaysia)



LGS Frames Structure



LGS Frame before installation



LGS Frames Structure

Installation: Superstructure (LGS Frames,walls and roof structure)

1. LGS Frames component produced at the factory.
2. Pre-assembled frame sections in factory or on-site.
3. Site preparation – i.e: R.C raft foundation slab casting before LGS assembly on site.
4. Deliver to the site in modular panels or bundle form.
5. On-site Installation – Electric Drill & Screws Fixing.



LGS frames deliver to site in bundle



LGS frame installation using electric drill



LGS frames at site



LGS frames at site ready to install



LGS frames installation for landed house on RC Slab foundation

3) Architectural (PRIMA Fibre Cement Boards)

- Primarily uses high quality PRIMA fibre cement products in form of board and planks
- All dry construction making the house faster & lighter to build.
- Comply with local & international material standard (i.e SIRIM, BOMBA & CIDB)
- Form the house or building envelope (wall) protecting it from heat & rain
- Thick fibre cement applied to the floor as lightweight floorboard (elevated slab)
- Medium-thick fibre cement used as the walls, gable ends, roof sarking, skirting, decorations and fascia board.
- Thin fibre cement used as ceiling & roof eaves.

Special Features

- Lightweight walls with less dead load
- Water & weather resistant
- Class 'O' material – fire safety
- Easy to handle, install and transport
- Anti termite
- Anti-fungus or mold
- Durable and strong
- Heat resistant
- High acoustic performance with insulation (optional)
- Aesthetically pleasing looks
- Flexible to receive finishes (paint, waterproofing, tiles, wallpaper & etc)
- Green building material certified
- Easy maintenance & replacement



Properties

Values

Product Composition

- Top Grade Cellulose Fibre
- Finely Ground Sand
- Portland Cement
- Water

Nominal Density

EMC= **1390kg/m³**

Moisture Content

EMC= **7%** Saturation = **33%**

Moisture Movement

0.08% (EMC to Saturated)

Minimum Bending Strength, MoR

DRY \geq **14 MPa** ; WET \geq **7 MPa**

Average Modulus of Elasticity, MoE

DRY = **6GPa** ; WET = **4GPa**

Fire Rating

Class O Material (Certified by Bomba)
Tested to **BS 476, Part 6: 1989 & BS 476, Part 7: 1997**

Fungus Resistance

Passes (**ASTM G21**)

Termite Resistance

Resistance to Damage (Field evaluation conducted by CSIRO)

Frost Resistance

Passed (**AS/NZS2908.2, MS 1296, ISO 8336, BSEN 12467, ASTM C1186**)

Heat Rain Resistance

Passed (**AS/NZS2908.2, MS 1296, ISO 8336, BSEN 12467, ASTM C1186**)

Product Standards & Certifications



BOMBA Class 'O'
(UBBL Malaysia)
Fire Resistance and
Compliance to UBBL's
Requirement



CIDB PPS (Bahan Binaan)
Approved by CIDB in accordance
to Akta Lembaga Pembangunan
Industri Pembinaan Malaysia 2011



Malaysian Standard MS1296:2010
Product Standard &
Quality Assurance



SIRIM Product Listing
Local Manufacturer &
Quality Assurance



MyHIJAU Certification
Malaysian Green
Technology
Corporation



SIRIM ECO Label
Green & Sustainable
Building Material
GBI Contribution



Termite Resistant



Fire Resistant



Water Resistant



Weather Resistant



100% Asbestos free



Superior Paint
Adhesion



High Workability



Aesthetically
Pleasing



50 Years Durability

Product Benefits & Advantages



Fire Safety

Fire safety is one of the most important aspects to be considered when it comes to constructions. Under certain circumstances, some houses are built extremely close to one another, such as those we have often seen in fisherman villages. As most of these houses were swiftly built using timbers, a small fire could easily trigger a catastrophic disaster for the occupants. To improve fire safety, PRIMA fibre cements boards can be used as the replacement for timber products that are used in conditions such as the above mentioned. PRIMA fibre cement boards are certified by the Fire & Rescue Department of Malaysia as a 'Class-O' material, complying with BS 476: part 6: 1989 & Part 7 :1997.



Green Sustainability

PRIMA fibre cement boards are made of portland cement, sand and cellulose fibre. The products are manufactured in accordance with the quality management system (QMS) ISO 9001:2008, holds an Environmental Product Declaration according to ISO 14025, MyHijau Cert. and SIRIM ECO Label.



Quality Assurance

PRIMA fibre cement products are manufactured in Malaysia in an ISO 9001 , and ISO 14001 certified manufacturing plant that is 100% asbestos-free. The products are distributed in more than 30 countries with strict adherence to each country's local industries standards.



Standards & Statutory Compliant

PRIMA products were tested accordingly to the MS1296:2010 standard and certified as a safe building material to use. This is in compliance to CIDB PPS statutory requirement enforced under the CIDB Act 2014 (Act 520).

PRIMA Fibre Cement Application Guide in Village Homes Design

> External Applications

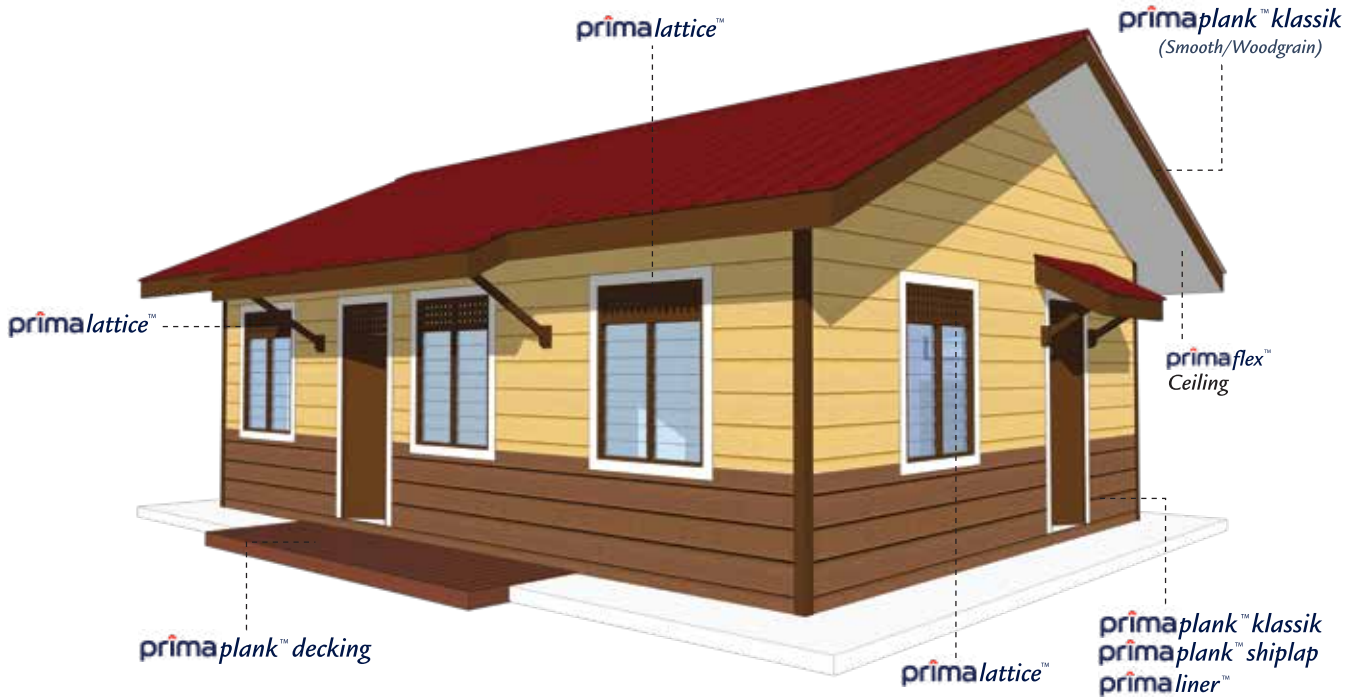

PRIMAplank doesn't just offer durability to a home but also aesthetics of the traditional or cottage-like look to a house exterior. With a 'wood-grain' textured surface, the PRIMAplank range offers the premium feel but also affordability with it.

> Internal Applications

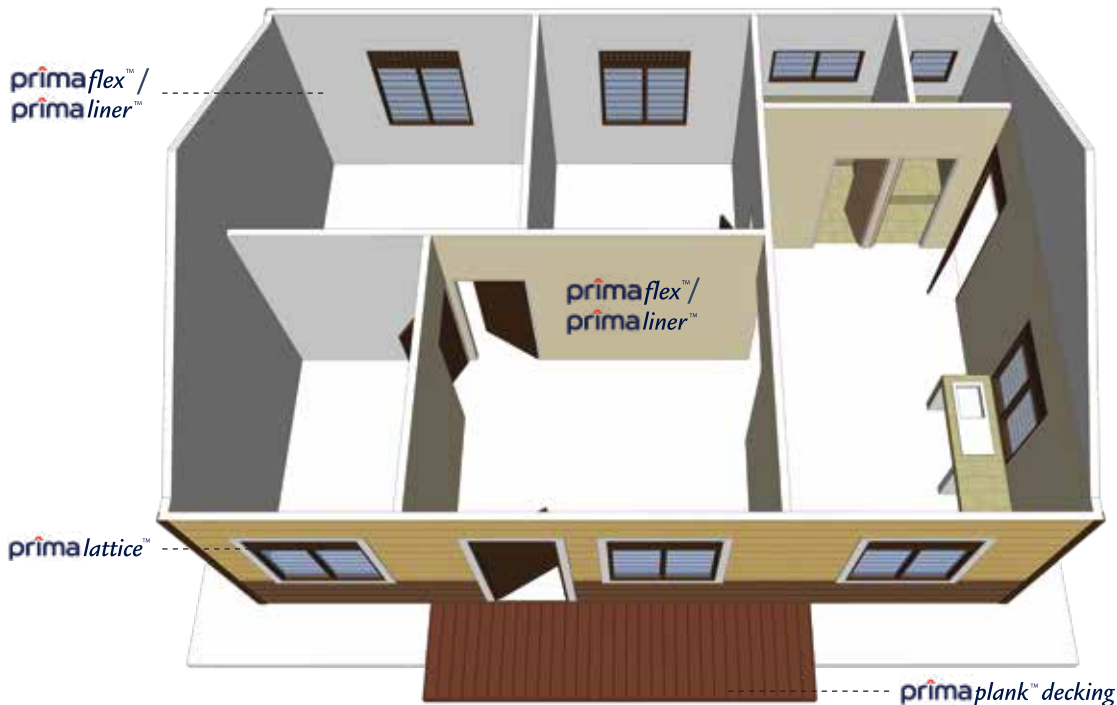

The synergy achieved through the combination of PRIMAliner as the main material for interior and PRIMAplank for the exterior results in a clean, yet beautiful look in the PRIMA IBS Homes. An IBS that has the aesthetics spot on coupled with its ease of construction and easy maintenance is just the right solution for all IBS builders in the industry.

The above applications are a guideline for reference only, please refer to PRIMA team for actual proposal.

PRIMA Fibre Cement Application Guide in Modern Homes Design

> External Applications

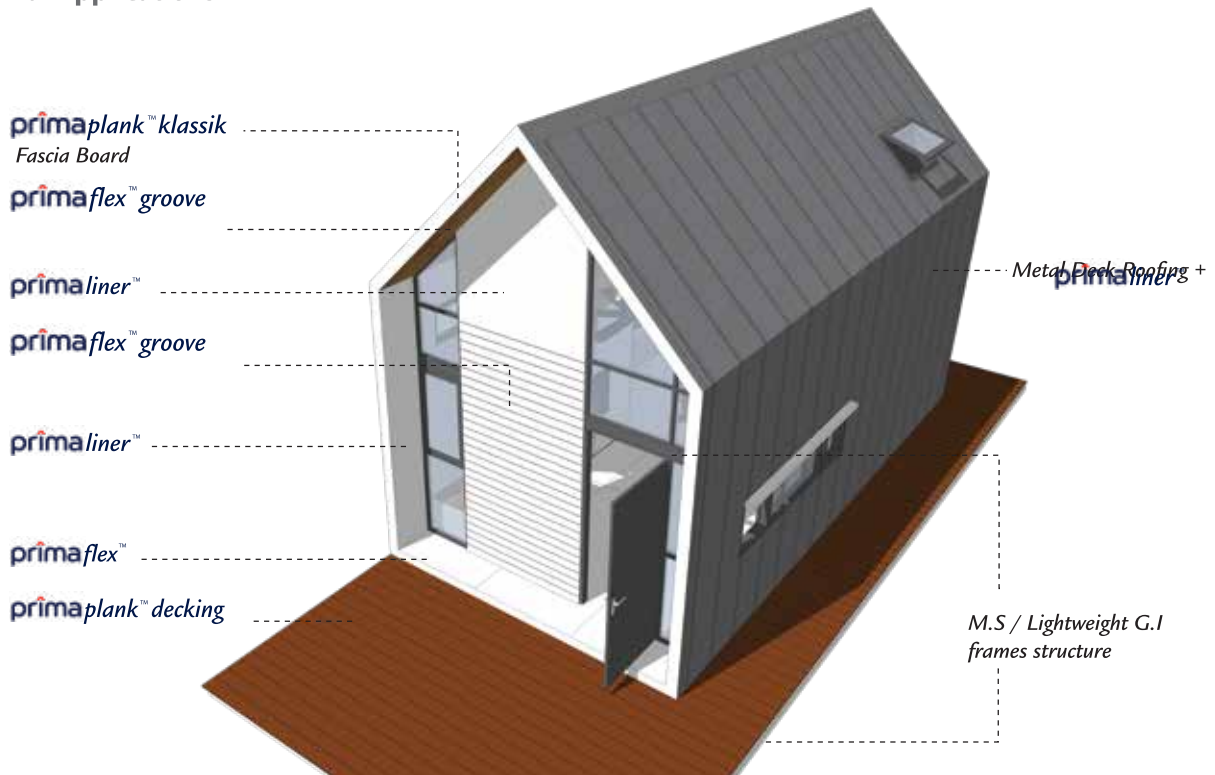

The minimalist yet modern design has been the trending home building trend over the years and this will go on for years to come. With the PRIMA IBS Homes Solution, you will have the complete package in 1 solution. A minimalist design featuring clean lines, modern yet trendy design and most importantly maximizing space efficiency while having an outdoor space and contemporary decking to it. Nothing else comes close to this.

> Internal Applications



The neat finishing, precise built and space efficiency of the PRIMA IBS Homes can be easily further optimized with the flexibility to add any built-in furnitures or interior designs. Good built & workmanship can be achieved due to its simplicity of construction.

The above applications are a guideline for reference only, please refer to PRIMA team for actual proposal.

Installation: General Construction Flow

PRIMA Solutions IBS Homes is a plug & play concept emphasizing on lessening the working hassle with ready made materials. Its ease of construction just by following the simple instruction shown in the manual will allow contractors to complete the IBS Homes with lesser manpower and shortened time.

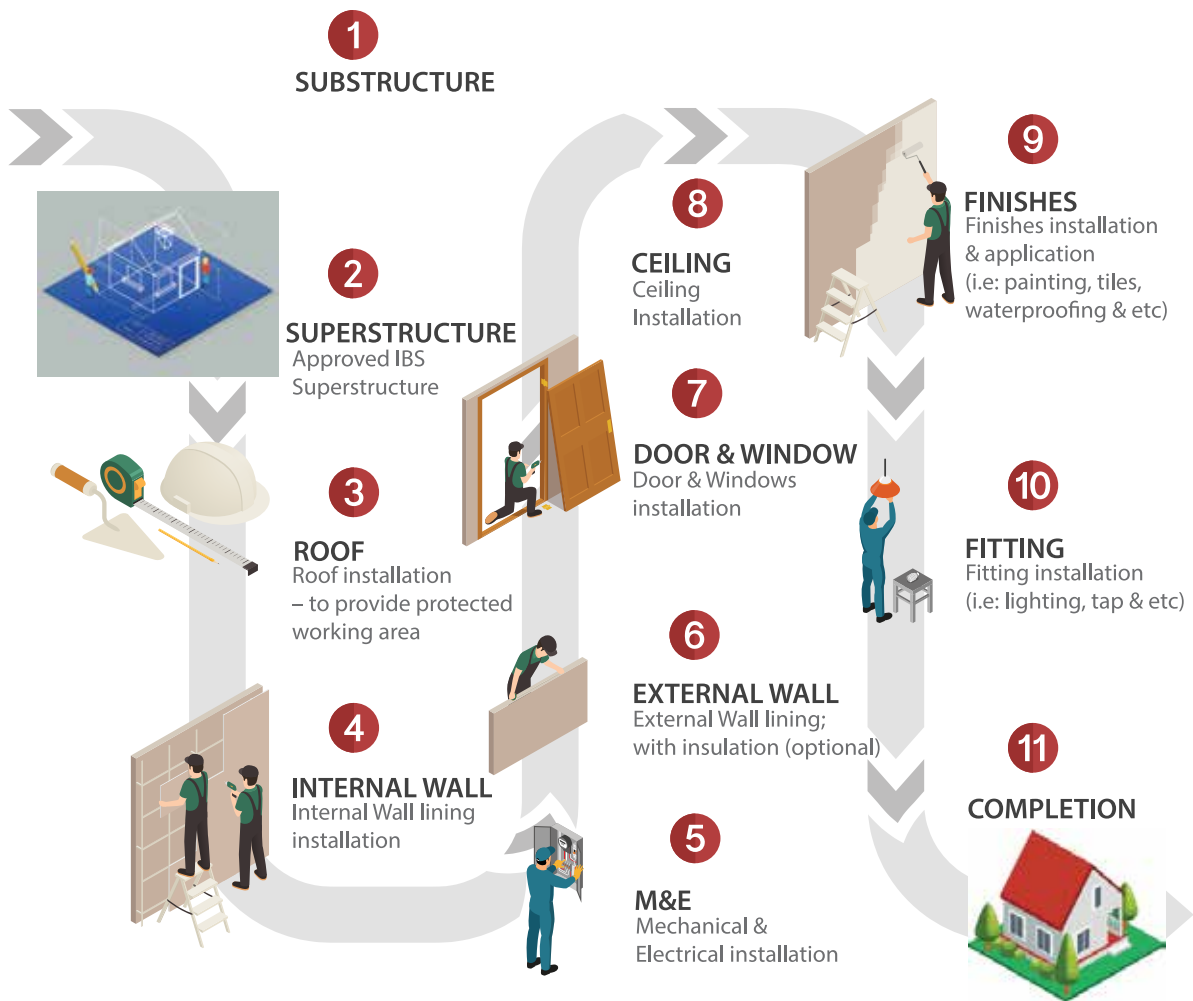

(Note: Sequence of works may vary depending on the house design, method of installation, on-site condition & others)



Roof installed on LGS frames to protect working area



Roofing insulation

Installation: Architectural (Building Envelope)

Once the wall frames and roofing works completed, the IBS house is ready for its architectural element installations.

Starts with external wall as building envelope, PRIMA Liner & Planks wraps the house parameter. The use of PRIMA fibre cement product will ensure weather tightness, sound & heat protection to the house.

Under Architectural element, few components to be constructed which includes;

- 1) External walls (cladding)
- 2) Internal walls (dry & wet)
- 3) Ceilings
- 4) Roof eaves & Fascia boards
- 5) Doors & windows
- 6) Finishes (Tiling & painting)



Sisalation sheets on LGS frames before install PRIMA fibre cement boards Wall insulation (optional)



PRIMA Flex as internal wall

PRIMAplank Klassik as external wall cladding



PRIMAplank Shiplap and PRIMA Flex as external wall cladding



PRIMA Flex as external wall cladding

Installation: Architectural - Roof Eave Ceiling - PRIMA Flex

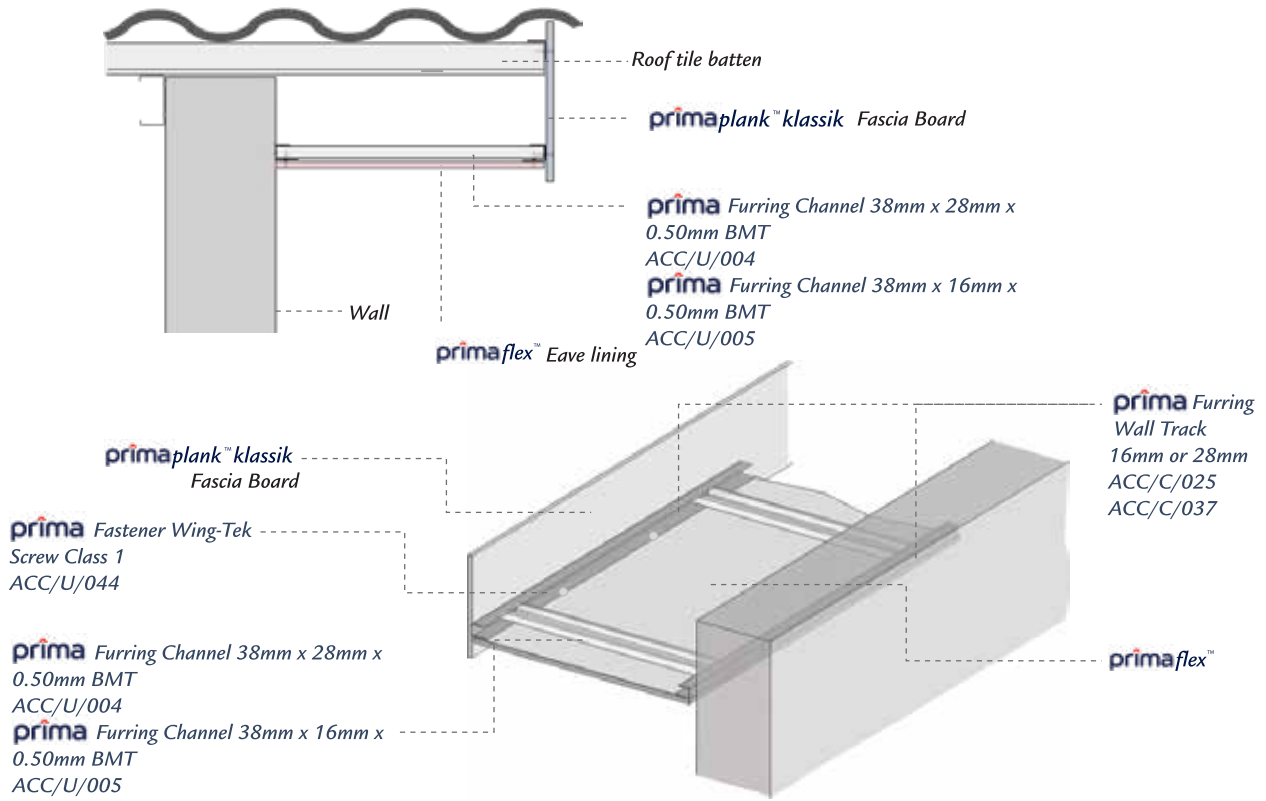

Remark :

The above diagram is a guideline for installation only and shall not be treated as construction drawing. Please refer to the latest PRIMA Technical Manual prior to the installation.



PRIMAplank Shiplap as external wall cladding



PRIMAplank Klassik as fascia board & PRIMA Flex as ceiling

Installation: Architectural - Cladding - PRIMAp plank Klassik

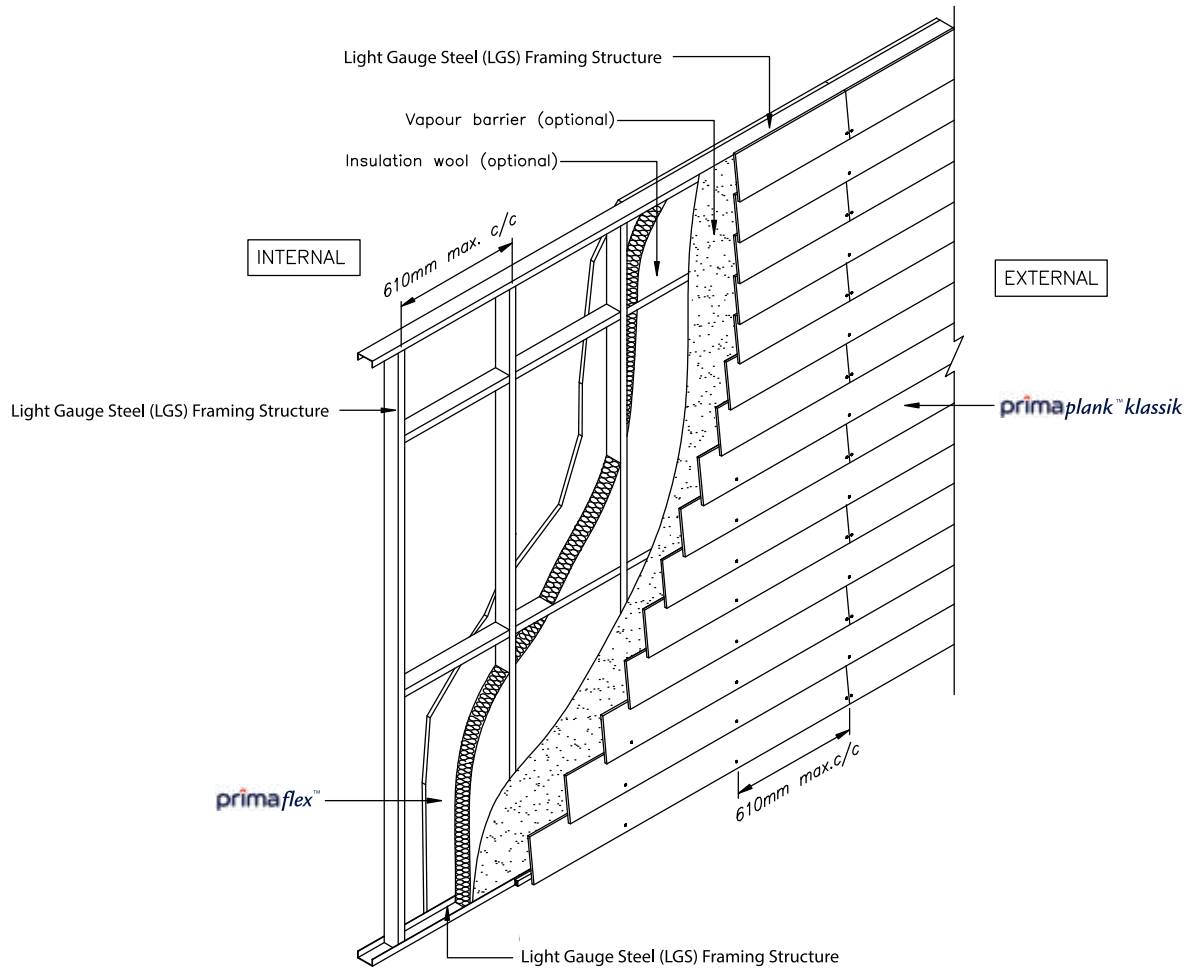

Remark :

The above diagram is a guideline for installation only and shall not be treated as construction drawing. Please refer to the latest PRIMA Technical Manual prior to the installation.

Special Features

- PRIMAp plank Klassik or PRIMAp plank Shiplap used as external cladding.
- Available in "smooth surface" (for modern siding appearance) and "woodgrain texture" (for premium timber profiling).
- Strong and durable fibre cement board reduce chances for surface damages (physical).
- It will neither warp nor become twisted when exposed to the weather.
- Fire resistant material for fire safety.
- Easily paint on-site using standard indoor emulsion paints.



Installation: Architectural - Cladding - PRIMA Boards



PRIMAplank Shiplap as external cladding



PRIMAplank Shiplap as external cladding



PRIMA Flex as external cladding



PRIMA Lattice as ventilated walls



prima plank™ klassik

Installation: Architectural - PRIMA Drywall

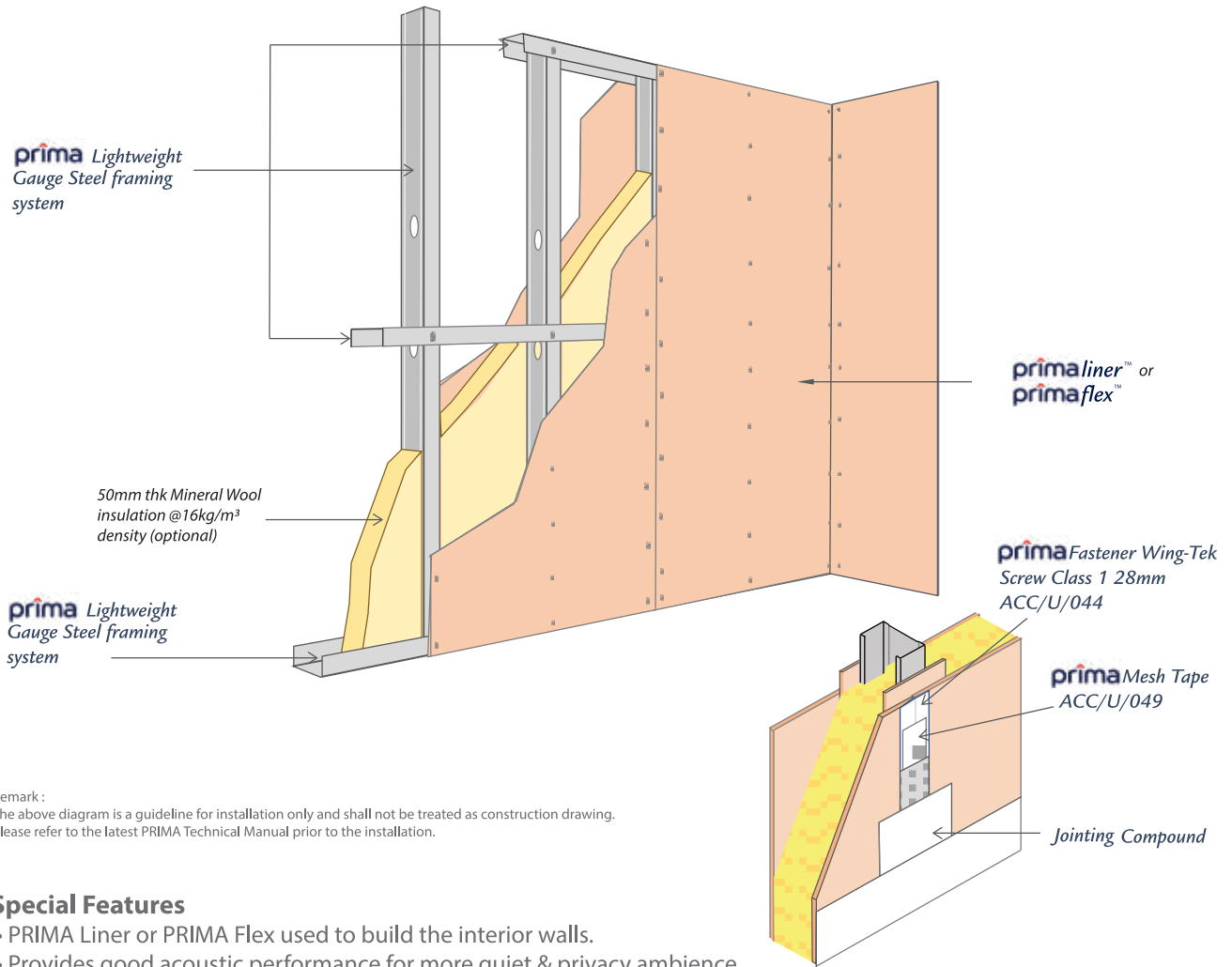

Remark :
The above diagram is a guideline for installation only and shall not be treated as construction drawing.
Please refer to the latest PRIMA Technical Manual prior to the installation.

Special Features

- PRIMA Liner or PRIMA Flex used to build the interior walls.
- Provides good acoustic performance for more quiet & privacy ambience
- Strong & durable fibre cement board reduce chances for surface damages (physical)
- Can be either butt-joint or flush joint (seamless) - Special compound is required
- Electrical outlet can be concealed (with special electrical point box) or exposed (standard box type)
- Fire resistant material for fire safety
- Anti mould features create a safer and healthier living environment
- Enables any wall-mounted fixture i.e Air conditions, Kitchen cabinets, Wash basin (Correct method applies)



PRIMA Liner as interior walls

Installation: Architectural -Wet Area Walls - PRIMA Liner

With bathroom and toilets that are commonly located inside the house, it is very important to make sure the walls and floors are water tight. PRIMA fibre cement is a water resistant material allowing it to be used in wet areas.

However, it is highly recommended for the installation to apply a suitable waterproofing system (by others) onto PRIMA fibre cement in wet areas.

PRIMA fibre cement walls and floors are also suitable for tile finishes. Cementitious tile adhesive is recommended to be used as a bonding agent where the normal cement mortar is not preferable.



Kindly consult PRIMA technical services team for more information.



Scan to Watch
Wet Area Video



Step by Step Guide

-  PRIMA Liner
-  Liquid applied waterproofing membrane
-  Elastic waterproofing sealing tape
-  (Wall) Ready-to-use tile adhesive in paste
-  Neutral-curing silicone sealant (Floor)
-  Epoxy based tile grout for joints from 1 to 15mm width
-  Deformable cementitious tile adhesive

**Diagram is just for illustration purpose only.*

**Please consult waterproofing specialist for the waterproofing system. Actual applications may vary according to building requirements and regulations*



Tiling on PRIMA Liner



PRIMA Liner is applicable for the wet areas such as washroom



Installation: Architectural - Ceiling System (Light Duty)

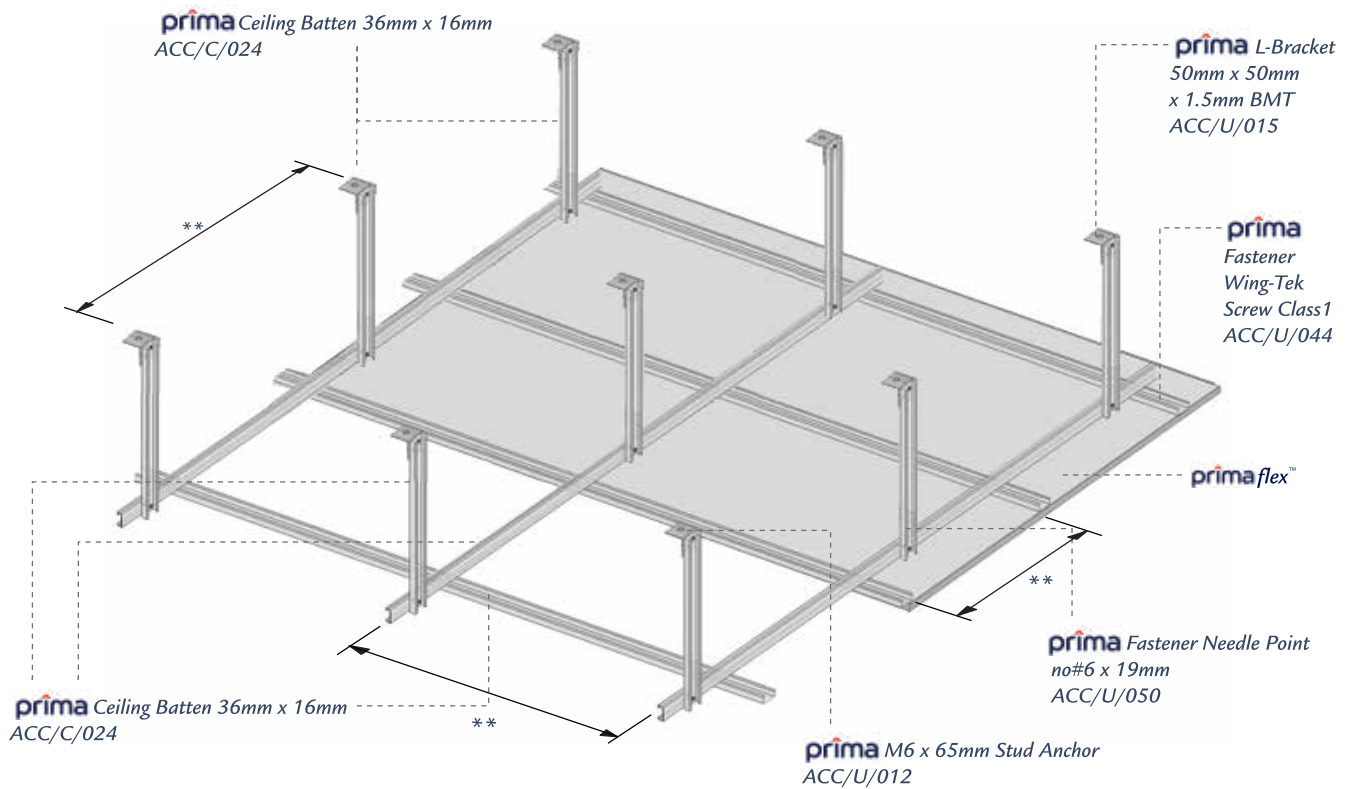

**

Remark:

The above diagram is a guideline for installation only and shall not be treated as construction drawing. Please refer to the latest PRIMA Technical Manual prior to the installation.

Special Features

- PRIMA Flex board used to build the ceiling and roof eaves
- Lightweight & economical solution for low-cost homes
- Water resistant material for more lasting ceiling
- Good heat resistant create comfortable indoor living
- Multiple sizes available to suit design preferences and construction methods
- Joints can be either butt-jointed or finished with timber beading
- Easily paint on-site using standard indoor emulsion paints



PRIMAFlex as internal ceiling with timber beading (optional) for neater termination



Fittings installed to the ceiling as per manufacturer's recommendation

Installation: Architectural - M&E System Wall

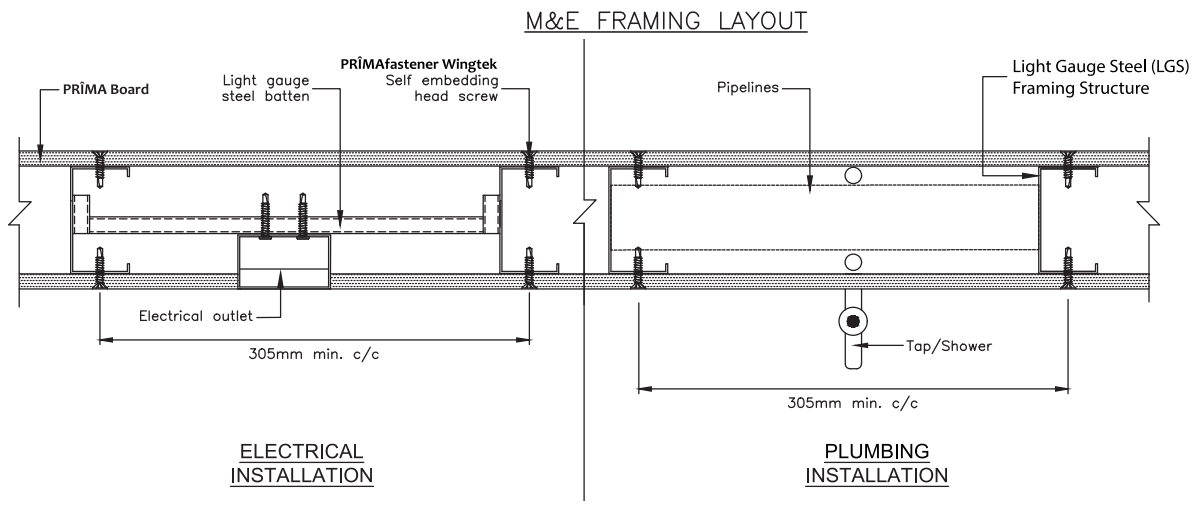
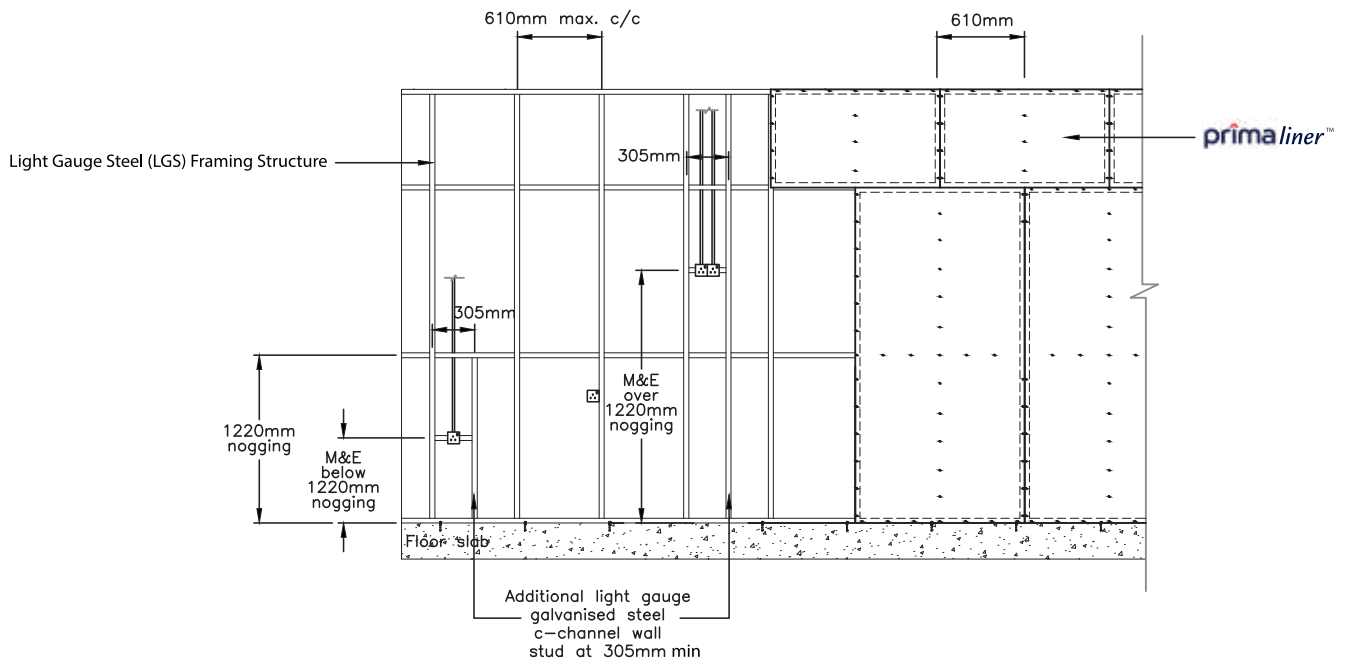

Remark :
The above diagram is a guideline for installation only and shall not be treated as construction drawing. Please refer to the latest PRIMA Technical Manual prior to the installation.



Use of specific 'clip-on' power socket (embedded type) for drywall (optional)



Wall switch and DB box on PRIMA Board



Main meter box installed on PRIMA IBS wall

Installation: Architectural - Interior Finishing



Seamless interior walls at Living Hall

PRIMA Liner compliments your assets with superior durability, providing a smooth and unified wall finishing. PRIMA Liner can be used internally for both dry and wet area applications where the seamless joint finish is a prerequisite. Produced with rebated edges on both sides of its length, installers can easily create a neat flush joint without much effort. PRIMA Liner is a premium board compared to gypsum or timber and ideal for building demanding high-performance sheeting.



Living hall walls with emulsion paint finish



Master Bedroom

Installation: Architectural - Interior Finishing



Bedroom



Wardrobe on PRIMA Liner wall



Rooms



Tiles on PRIMA Liner wall



Kitchen Area



Living Room



Kitchen Area



Kitchen Area



 PPS (BAHAN BINAAN) No. Pendaftaran: 1150993SL0387 1150919P00384	 BAHAN KELAS 'O' BS 476 - PART 6 : 1989 BS 476 - PART 7 : 1987	 MyHP00175/16	 SINGAPORE GREEN BUILDING PRODUCT EXCELLENT CERT. NO. : SGBP 5989	 SIRIM ECO-LABEL License No. ELH0006001	 MS CERTIFIED TO MS 1286 : 2010 Certification No. PH 000605	 SIRIM CERTIFIED TO ISO 9001 : 2015 CERT. NO. : QMS 00214	 SIRIM CERTIFIED TO ISO 14001 : 2015 CERT. NO. : EMS 00481	 SIRIM CERTIFIED TO OHSAS 18001 : 2007 CERT. NO. : OHS 00286	 MS Certified to ISO 8338:2009 Certification No. PH000913
 Termite Resistant	 Fire Resistant	 Water Resistant	 Weather Resistant	 100% Asbestos free	 Superior Paint Adhesion	 High Workability	 Aesthetically Pleasing	 50 Years Durability	

For more information, please contact us at:



SAINT-GOBAIN PRIMA SDN BHD (579898-W)

Level 19, Tower 5, Avenue 7 The Horizon,
 Bangsar South City, No. 8, Jalan Kerinchi,
 59200 Kuala Lumpur, Malaysia

General Line 1: +603 7781 1977 | General Line 2: +6012 781 1797

www.saint-gobain.my

[f](#) [in](#) [v](#) [p](#) [t](#) [s](#) [y](#) saintgobainprima