



prima plank[™]
TECHNICAL MANUAL

CONTENTS



Designed to attain pure luxury

Aesthetic Cladding | Decorative Fencing | Gable End Cladding | External Wall Cladding | Fascia Board | Decking | Flooring | Ceiling | Eaves Lining

1. Introduction ————— 03

- 1.1 General
- 1.2 Applications
- 1.3 Features & Benefits
- 1.4 Tests and Certification

2. General Fixing Instructions ————— 03

- 2.1 Material Selection
- 2.2 Framing Specification
- 2.3 Fasteners
- 2.4 Sealing Joints & Gaps
- 2.5 Jointing Against Other Materials

3. External Wall & Gable End Cladding ————— 04

- 3.1 General
- 3.2 Framing Construction
- 3.3 Flashing
- 3.4 Sarking
- 3.5 Plank Overlaps
- 3.6 Installation Procedures
- 3.7 Fixing to Timber
- 3.8 Fixing to Steel
- 3.9 Joints
- 3.10 Ground Clearance
- 3.11 Corners
- 3.12 Details at Openings

4. Cladding to Masonry Wall ————— 10

- 4.1 General
- 4.2 Battening Requirement
- 4.3 Installation Method
- 4.4 Sarking
- 4.5 Jointing
- 4.6 Wall to Eaves Junction

CONTENTS

prima plank[™]

Designed to attain pure luxury

Aesthetic Cladding | Decorative Fencing | Gable End Cladding | External Wall Cladding |
Fascia Board | Decking | Flooring | Ceiling | Eaves Lining

5. Fascia Board ————— 11

- 5.1 General
- 5.2 Support
- 5.3 Installation
- 5.4 Joints

6. Decorative Fencing ————— 12

- 6.1 General
- 6.2 Framing Requirement
- 6.3 Installation

7. Ceiling & Eaves Lining ————— 13

- 7.1 General
- 7.2 Framing Requirement
- 7.3 Installation

8. Decking / Flooring ————— 15

- 8.1 General
- 8.2 Framing Requirement
- 8.3 Installation

9. Finishes Recommendation ————— 18

10. Working Instructions ————— 18

- 10.1 Cutting
- 10.2 Drilling
- 10.3 Handling & Storage

11. PRIMA Accessories ————— 19

- List of Components

1 Introduction

1.1 General

prima plank™ is an autoclaved cellulose fibre reinforced cement siding board that is manufactured from an ISO 9001 and 14001 certified plant. It is made of Portland cement, finely ground sand and water. **prima plank™** has become extremely popular when a relatively maintenance free timber planking appearance is desired.

1.2 Applications

prima plank™ is designed for external applications where superb weatherability and long-lasting durability form part and parcel of performance criteria. These applications includes:-

- External wall cladding
- Gable end cladding
- Aesthetic cladding
- Fascia board
- Gate and fencing
- Ceiling
- Skirting
- Floor and Decking

prima plank™ is used where there is a requirement for traditional timber look and to add character and depth to flat mundane surfaces.

1.3 Features & Benefits

- Natural timber look
- Weather resistant
- Will not rust or rot
- Termite resistant
- Does not warp or twist
- Fire resistant- Class 'O'
- Aesthetically Pleasing
- Environmentally Friendly

1.4 Tests and Certification

prima plank™ meets the national & international fibre cement standards, namely MS 1296, ISO 8336, AS/NZS 2908.2, BSEN 12467 and ASTM C 1186.

1.4.1 Serviceable Life

When installed and maintained as per good building practice and specifications described in this manual, **prima plank™** is expected to have serviceable life of 50 years.

1.4.2 Standard Sizes and Mass

prima plank™ comes in standard thickness of 7.5mm to 16mm. It is available in three patterns:



prima plank™ - Smooth
is available with a flat unsanded surface.

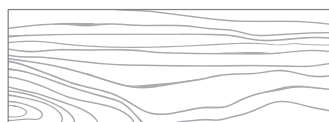

prima plank™ - Woodgrain
has an enhanced timber texture on the front surface.



prima plank™ - Timbergrain
is straight grain timber texture, available on front surface.

2 General Fixing Instructions

2.1 Material Application

prima plank™ thickness should be selected based on the intended applications. For general cladding, fascia board and fencing applications, 9mm thick plank is the minimum.

Refer to **prima plank™** product brochure for information on applications based on product thickness, standard length and width dimensions and texture profile.

Trimming plank to a size less than the standard width will reduce its capacity to withstand loads. In instances where reduced-width planks are desirable such as for fencing application, always refer to Hume Cemboard before specifying or applying them.

Do not apply **prima plank™** in areas where it remains in contact with standing water.

2.2 Framing Specification

prima plank™ can be applied to **timber** or **Light gauge steel (LGS)** framing members. Construction shall be in accordance with local building practice.

Framing components must have adequate durability for the intended use. These durability criteria shall among others include resistance to weather; corrosion and pest (i.e. termite attack).

Timber framing should be thoroughly dry and selected to minimize shrinkage when planks are installed.

Use **timber batten** with a minimum of **25mm** thick x **50mm** wide to allow adequate nail penetration.

Steel framing must be fabricated from cold-formed galvanized light gauge steel or zincalume steel of a minimum **0.50mm** to **1.15mm** base metal thickness.

Steel battens must have a minimum **35mm** face width. They are typically 'Z' or top hat sections.

As the straightness of finished wall is highly dependent on workmanship of framework, best result can be achieved when frame straightness is between **3mm** to **4mm** in any **3000mm** length.

2.3 Fasteners

Select the appropriate type of fasteners based on the type of framing. Fasteners should have acceptable level of durability and be suitably coated for the intended application.

At least class 3 fasteners must be used for external applications.

primaplank™ can be fixed by *hand nailing* or *air gun nailing*. For *screw fixing*, use *power tools* with high torque and variable speed of zero to **2,500 revolution per minute** fitted with a depth control attachment.

Nail head should finish flush with the **primaplank™** face and avoid overdriving.

Drive screw slightly below the plank face and cover fastener head with exterior grade **Jointing Compound**.
Smoothen with sandpaper if necessary before painting.

2.4 Sealing Joints and Gaps

Gaps at plank joints, corners and openings must be sealed with flexible / paintable polyurethane sealant. Sealant must be compatible with cementitious panel products. Apply **masking tape** at both plank edges and start filling the bottom edge and squeezing the sealant in the upward direction. Use **spatula** to smoothen and remove any excess sealant. Remove masking tape immediately upon completion.

2.5 Jointing Against other Material

When butt jointing **primaplank™** and other building materials such as masonry wall, a minimum of **6mm** gap must be provided. Seal gap with paintable / flexible PU sealant, as shown in **Figure 2.6.1**.

Table: Fastener Specification

Fasteners to Timber



2.8mm Ø x 30mm Galvanised Nails
2.8mm Ø x 40mm Galvanised Nails
(for plank thickness 16 & 25mm)

Fasteners to Steel



Self-embedding head, self-drilling
"Wing Tek's" Screws for fastening to
0.50mm to 1.15mm BMT steel frames
No.8 X 1 1/8" (28mm) for plank
thickness ≥ 7.5mm and up to 12.0mm
No.8 X 1 1/4" (32mm) for plank
thickness - 12mm & 16mm
No.8 X 1 3/4" (44mm) for plank
thickness >16.0mm and up to 25mm

Useful Tips:

1. Drive nail head until flush with plank face.
2. Pre-drilling is required when nailing between **20mm** to **50mm** from the plank end.
3. Drive screw heads not more than **1mm** below plank face.
4. Overdriven fastener point should be cover with exterior grade jointing compound before painting.
5. Hold plank firmly against the frame while driving the fasteners.

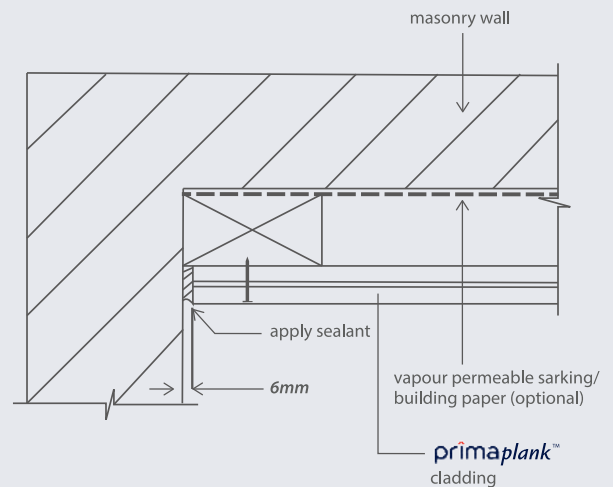

Figure 2.5.1: Jointing with other material

3 External Wall & Gable End Cladding

3.1 General

primaplank™ is suitable for general wall cladding application when a lightweight wall system is preferred. The usage includes construction of new buildings such as residential dwellings and resorts. In addition, **primaplank™** can also be used for renovation/extension of existing buildings especially in the construction of upper storey.

3.2 Framing Construction

primaplank™ must be supported at 600mm maximum centres. Refer **Figure 3.2.1**. The minimum stud face width shall be as follows:-

- Timber framing - **50mm** min.
- Steel framing - **35mm** min.

Timber framing is typically **50mm x 75mm** and light-gauge metal framing is typically **35mm x 64mm x 0.55mm** BMT**.

** to refer to Saint-Gobain Prima Technical Team for the ideal recommendation

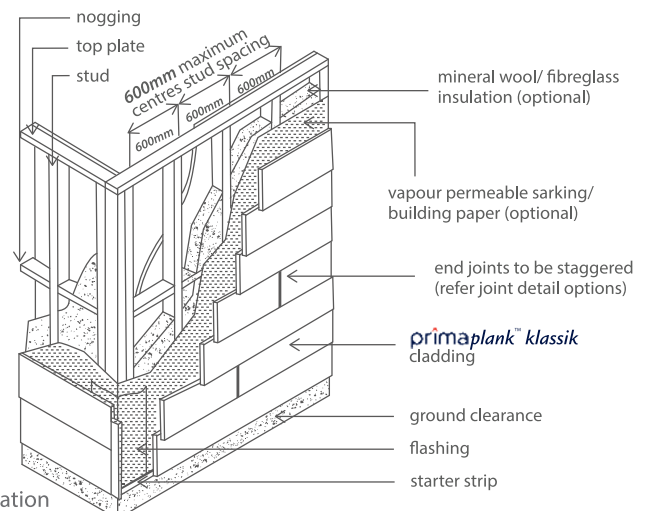

Figure 3.2.1: Horizontal planking

When on-stud jointing is preferred, stud face width must be increased to provide for adequate edge fixing distance. Use **frame off-cuts to pack stud** at plank joint if required.

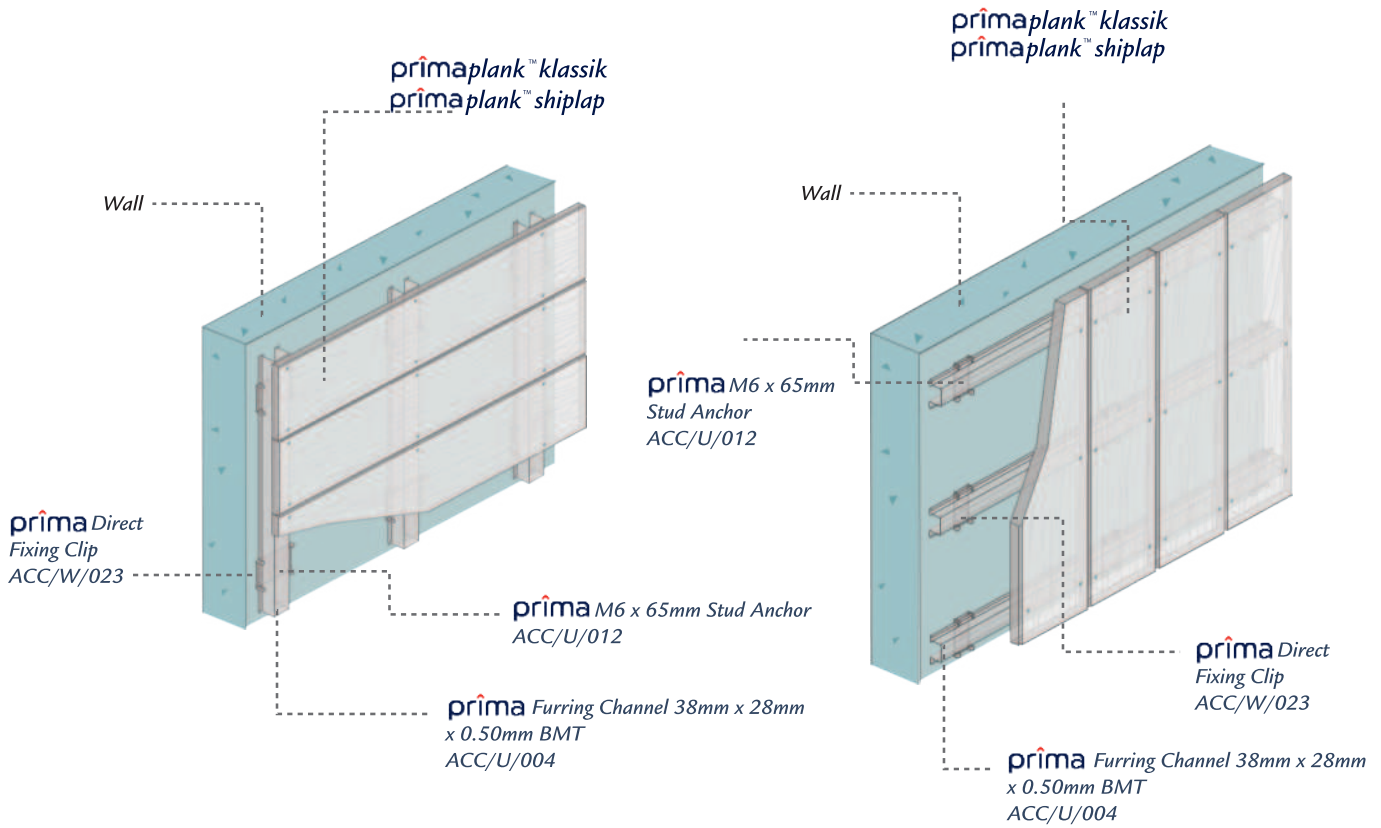

Figure 3.2.2: Direct Fixing Cladding System

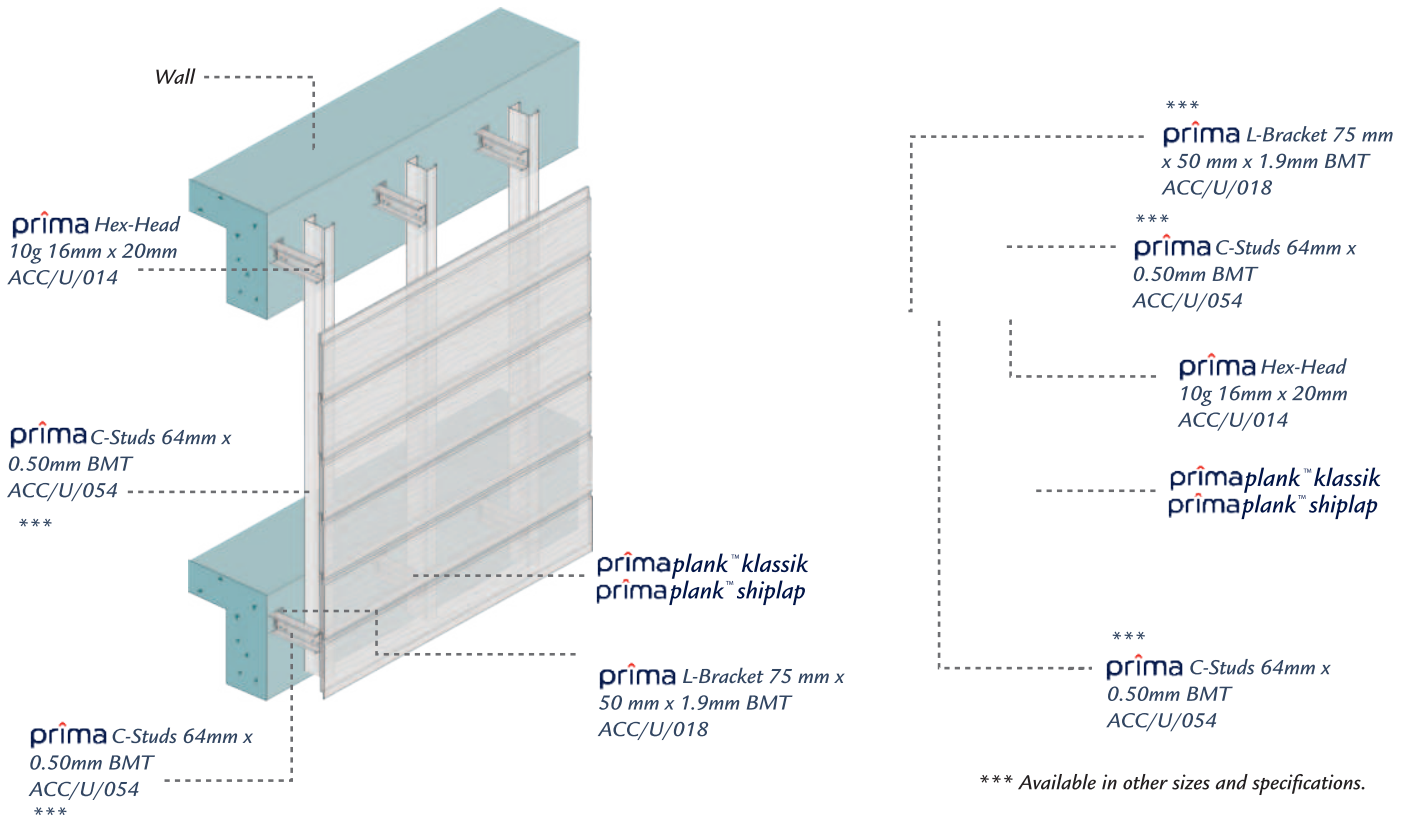

Figure 3.2.3: Cantilever Cladding System

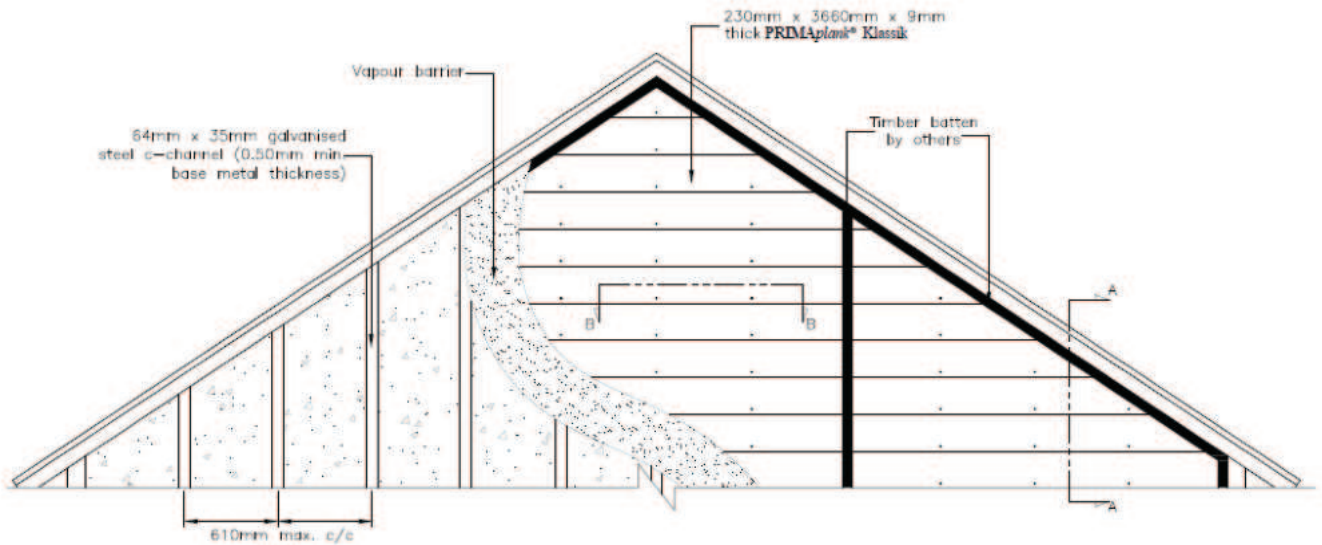

Figure 3.2.4: Gable End Diagram

3.3 Flashing

When applied as external wall cladding it is a good building practice to apply flashing material at corners, above the *head* and *under the sill of an opening*.

3.4 Sarking

During windy condition, the external pressure would generally be greater than the building's internal pressure. The pressure differential will likely draw water into the wall cavity through the plank's joints and laps. It is recommended to install *vapour permeable sarking* between *prima plank*™ and the framing surface. The use of *reflective sarking* will enhance the thermal insulation property of the cladding system.

3.5 Plank Overlaps

For external cladding applications, plank must overlap the previous course by a *minimum of 25mm*. Plank overlap may be increased to achieve the desired exposed plank surface. Higher overlaps may also improve the weatherproofing of a framed-wall particularly when sarking material is not applied. When necessary, overlap may be increased to obtain *full-course planking* to match the wall height.

To facilitate plank installation with consistent overlaps, use a *lap gauge*. A *lap gauge* can be fabricated from *prima plank*™ off-cuts or timber piece. Refer *Figure 3.5*.

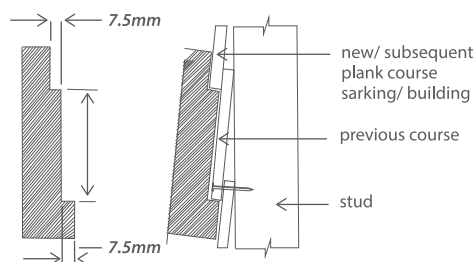

x = net cover width (plank width - overlap)
eg 230mm - 25mm = 205mm

Figure 3.5: *prima plank*™ Lap gauge

3.6 Installation Procedure

These steps provide a general guide for installation of *prima plank*™.

1. Ensure framing is *flat and align* prior to fixing *prima plank*™.
2. Apply *vapour barrier* over the framework.
3. Fix *flashing* at all internal and external corner and heads of openings such as *door* and *window*.
4. Install *timber moulds* at internal and external corners.
5. Secure a *40mm wide prima plank*™ starter strip or treated timber strip along the bottom plate.
6. Use a *spirit or water level* to locate the top edge of the first course of the plank.
7. Drive a series of *guide nails* around the *perimeter* of the timber framework to indicate the *top edge* of the first course of the plank.
8. Fix the first plank starting from the *external corner*. Set the *top edge* of the plank flush against the guide nails and the *end abutting* the (moderate contact) *timber corner stop*. Drive fastener to the *bottom plate* through the plank thickness and the starter strip at *200mm centres maximum*.
9. Fix the balance of the planks of the *first course* around the building. Planks may be joined with propriotor PVC jointer.
10. Provide a minimum of *25mm* overlap between each *successive* plank course. Measure the *total wall height* to be clad and calculate the suitable overlap so that a near *full-width* plank finishes at the *top of the clad wall*. Remove the guide nails and continue the next course of the plank with an off-cut plank. This is done to ensure that the plank joints would be *staggered between courses*.
11. Check *level* occasionally.

3.7 Fixing to Timber

When applied onto timber framing, *primaplank*™ must be nailed at centre of overlap through both thicknesses, as shown in *Figure 3.7*.

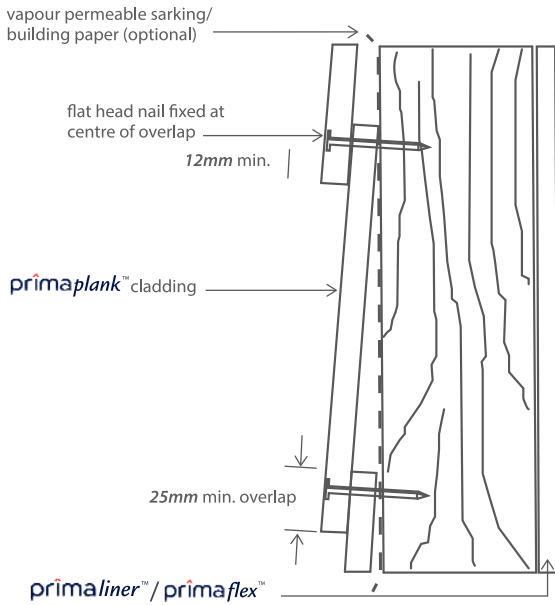

Figure 3.7: Fastening to timber frame

3.9 Joints

Joint options are shown below. When applied as *wall cladding*, plank joints should preferably be *staggered* between each plank course. *primaplank*™ "off-stud" jointing method incorporates proprietary *PVC jointer* between plank ends. Refer *Figure 3.9.1*.

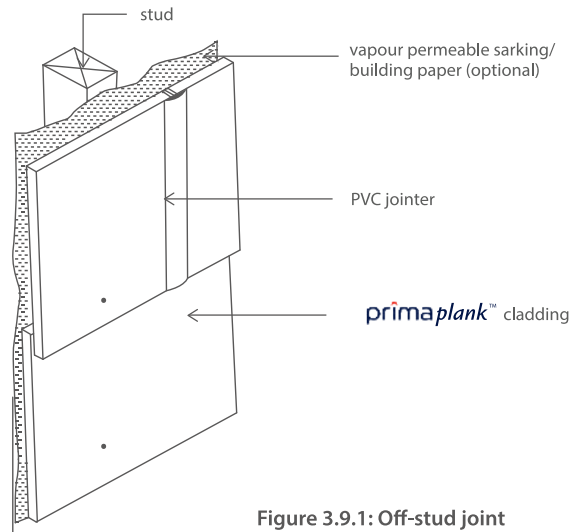

Figure 3.9.1: Off-stud joint

On-stud jointing can be done by *butt jointing* plank ends with moderate contact. Alternatively, provide a nominal *3mm* gap and seal joint with exterior grade paintable/ flexible sealant. Refer *Figure 3.9.2*.

3.8 Fixing to Steel

Planks are screwed to *light gauge steel framing* through the top plank only. Refer *Figure 3.8*.

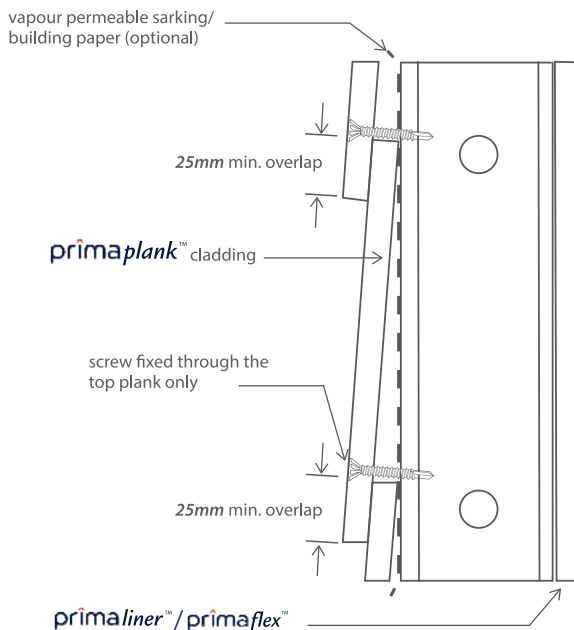

Figure 3.8: Fastening to steel frame

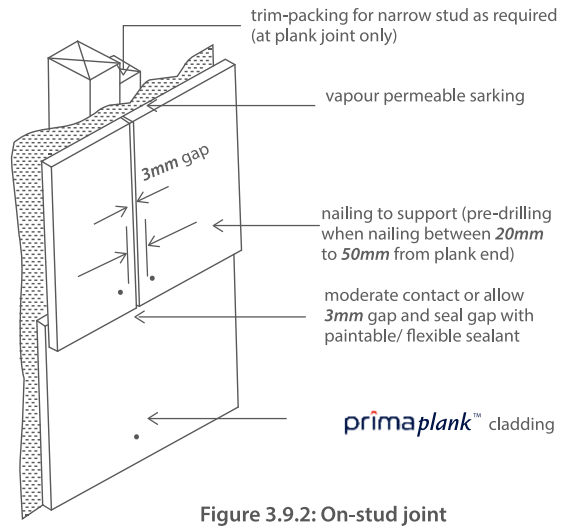

Figure 3.9.2: On-stud joint

3.10 Ground Clearance

Provide a minimum of **150mm** clearance between bottom edge of plank (or starter strip) and the earth as shown in **Figure 3.10**.

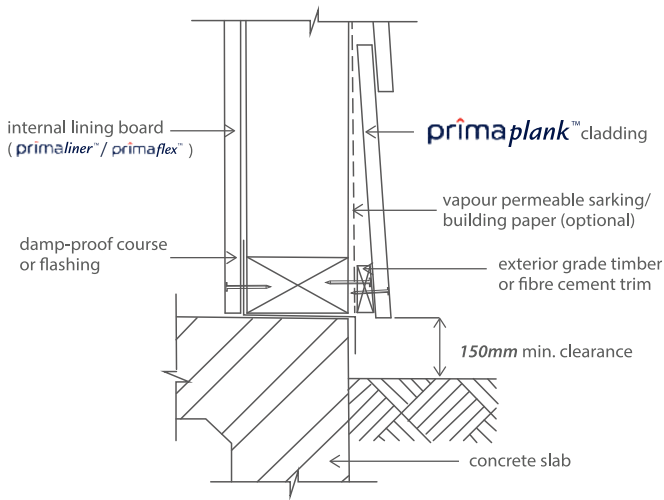

Figure 3.10: Ground Clearance

3.11 Corners

Internal and external corners may be finished with timber stops as illustrated in **Figure 3.11.1** and also metal accessories/trim (refer **Figure 3.11.3** and **Figure 3.11.4**).

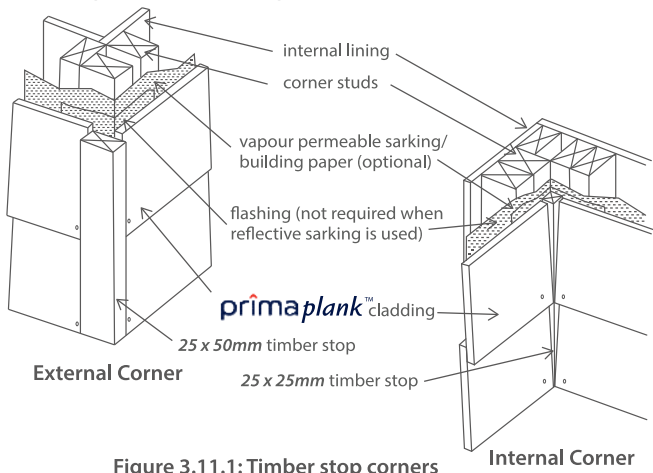

Figure 3.11.1: Timber stop corners

Alternatively, when timber posts are utilized, plank ends abutted to the side of the posts. Refer **Figure 13**.

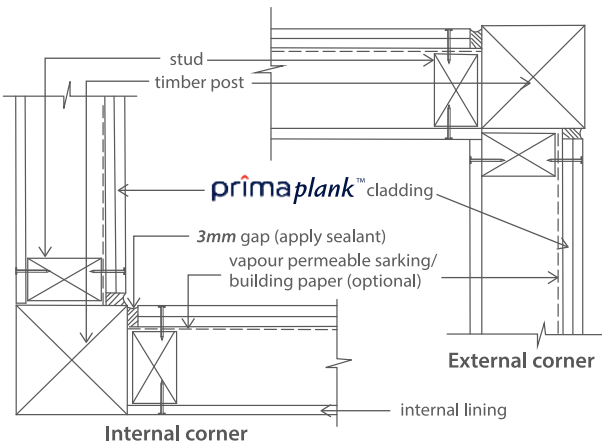

Figure 3.11.2: Timber post corners

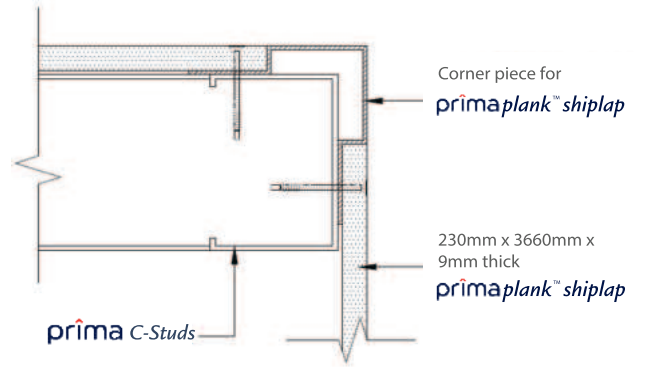

Figure 3.11.3: External corner solution corner piece

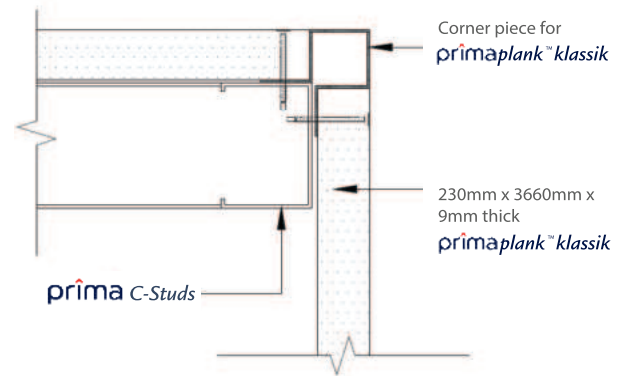

Figure 3.11.4: External corner solution corner piece

3.12 Details at Openings

When applying plank at around *window* or *door openings*, allow an approximately **5mm clearance** at the *sill*, *jamb* and *head*. Seal gap with paintable/ flexible sealant. Do not apply sealant between *head flashing* and *plank edge*.

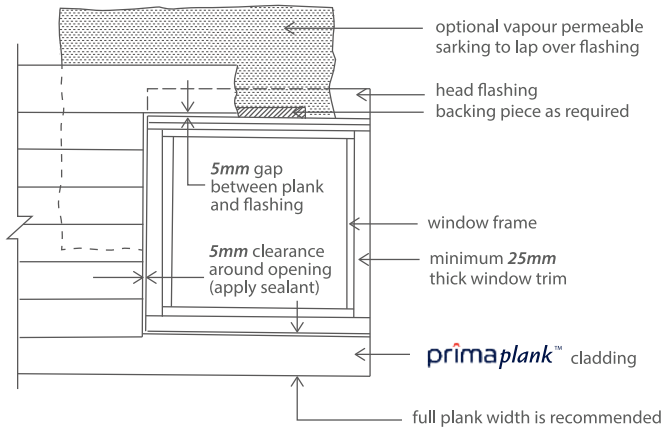

Figure 3.12.1: Window/ door opening detail

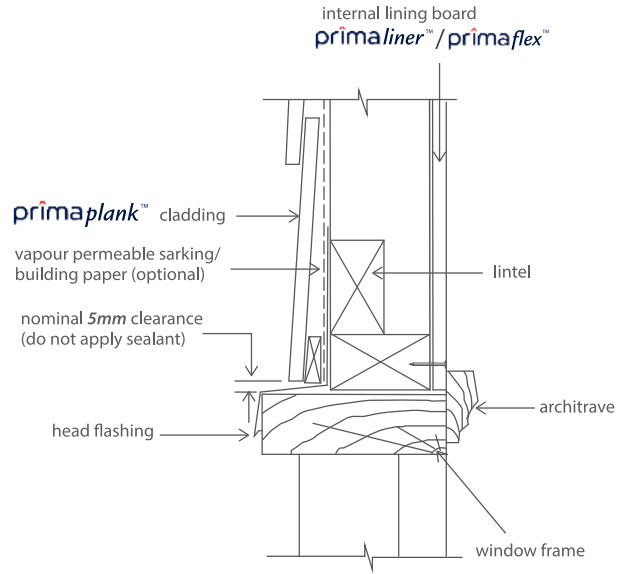

Figure 3.12.2: Head Flashing Detail

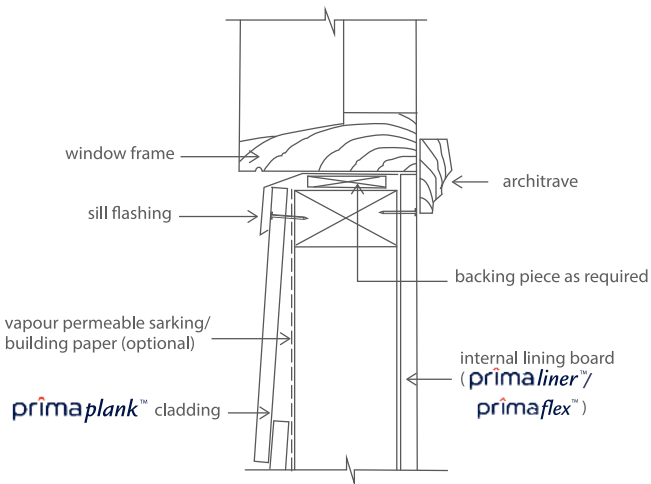

Figure 3.12.3: Sill Flashing Detail

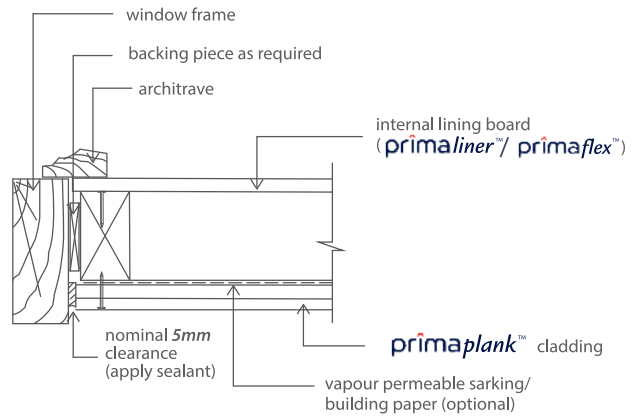

Figure 3.12.4: Door/ window jamb detail

4 Cladding To Masonry Wall

4.1 General

prima plank™ can be clad onto masonry wall to enhance the aesthetic appearance of residential or commercial buildings.

4.2 Battening Requirement

Masonry wall must be battened prior to applying **prima plank™**. Battens must be spaced vertically at **600mm** or **610mm** maximum centres. Ensure batten's straightness is within the acceptable tolerance. Battens must be adequately fastened onto the masonry wall.

4.3 Installation Method

prima plank™ may be installed horizontally. In any case, support must be provided at **600mm** or **610mm** centres. Installation method is similar to that of external cladding application.

Battens can be applied directly onto relatively flat/ even masonry wall. Refer **Figure 4.3.1**.

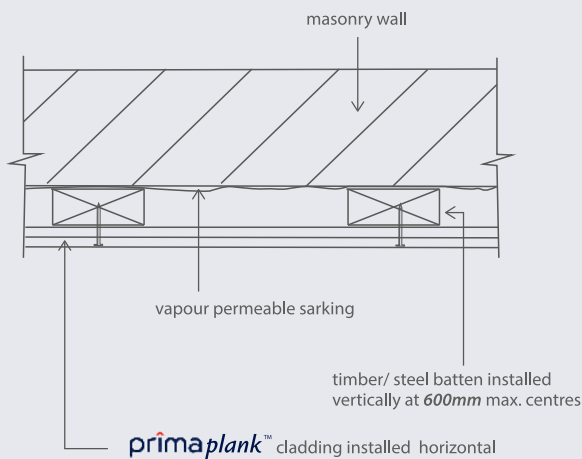

Figure 4.3.1: Battening onto flat masonry wall

Provide spacers or brackets when battening uneven masonry wall as shown in **Figure 4.3.2**. All framing components must be adequately secured onto masonry wall. Consult a qualified engineer to verify structural adequacy if required.

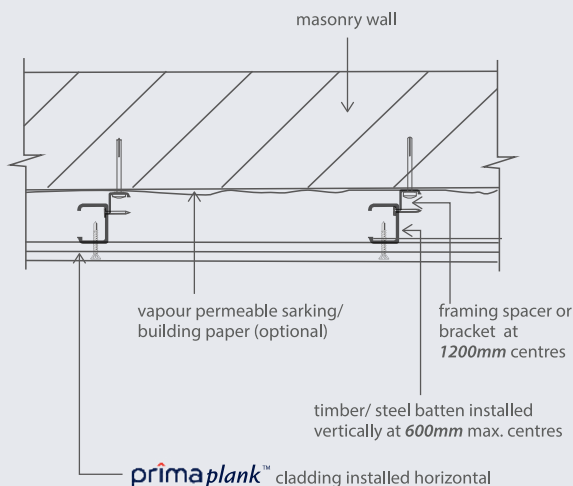

Figure 4.3.2: Battening onto uneven masonry wall

4.4 Sarking

It is recommended to install a **vapour permeable sarking** material on the masonry wall prior to fixing battens.

4.5 Jointing

Planks can be jointed with **PVC jointer** or **Butt Jointed**. These jointing methods are similar to the external cladding joints shown in **Figure 3.9.1** and **3.9.2**.

4.6. Wall to Eaves Junction

Provide adequate ventilation between masonry wall and **prima plank™** cladding. The ventilation can either be provided through the roof or below the eaves. Ventilated path through the roof is depicted in **Figure 4.6** below.

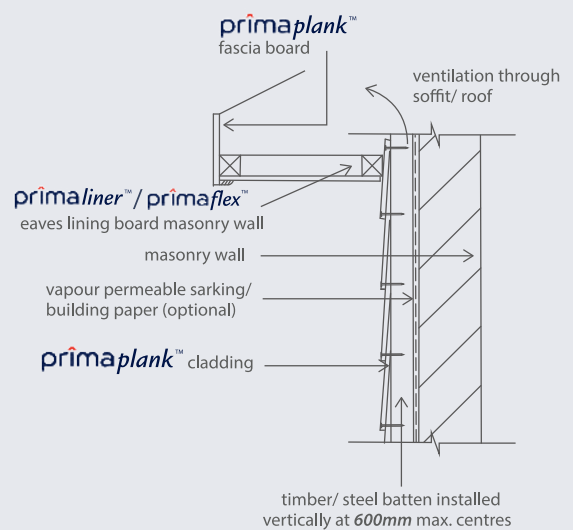

Figure 4.6: Wall ventilation detail

5 Fascia Board Introductions

5.1 General

prima plank™ superior durability makes it a perfect choice for *fascia board* around the roof perimeter. With the choice of *various surface* texture, **prima plank**™ fascia board is not only aesthetically pleasing but also cost effective.

5.2 Support

prima plank™ as fascia board is normally fixed to *timber or metal rafters/ trusses* with support spacing not exceeding **600mm centres**. When support spacing exceeds **600mm**, provide a continuous *battening* behind the fascia board. Alternatively, a 'dummy' *rafter/ truss* should be provided as intermediate support. The use of **9mm thick** plank is highly recommended when support spacing is more than **600mm** centres.

5.3 Installation

Apply a minimum of **2 fasteners** at each rafter or truss end. Drive fastener **12mm** from plank edge and **50mm** from corner.

Fix a *metal angle capping* at ends of metal *rafters/ trusses* to facilitate **prima plank**™ fascia board installation as described in *Figure 5.3*.

Fixings of attachment (such as *bracket for gutter*) to fascia board must be connected to the *roof structural element*.

5.4 Joints

Planks can be jointed with *PVC jointer* or *Butt Jointed*. Provide **3mm** gap if joint is to be sealed. These jointing options are shown in *Figure 5.3 & 5.4*. When *Off-support Joint* without *PVC jointer* is preferred, provide additional *metal/ timber backing piece* behind the fascia board. Ensure planks are secured to the *backing piece*. Hold *backing piece* firmly while driving the *fasteners*. Hold *backing piece* firmly while driving the *fasteners*.

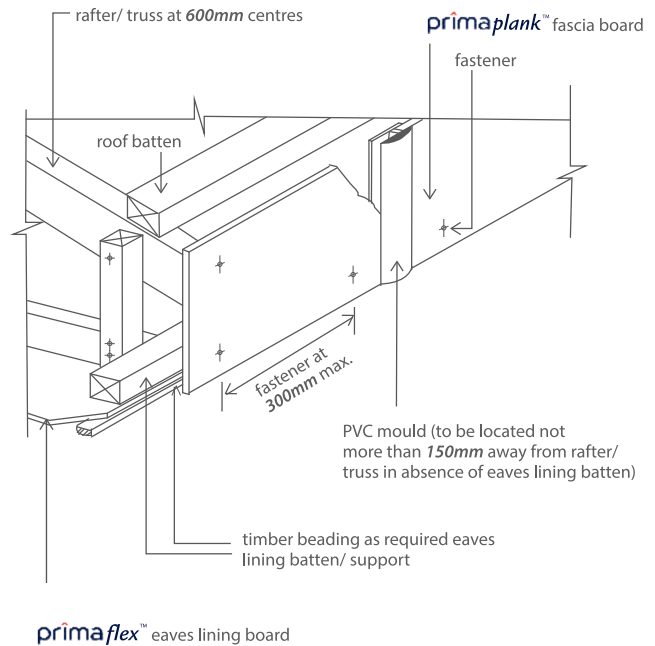

Figure 5.3: PVC joint

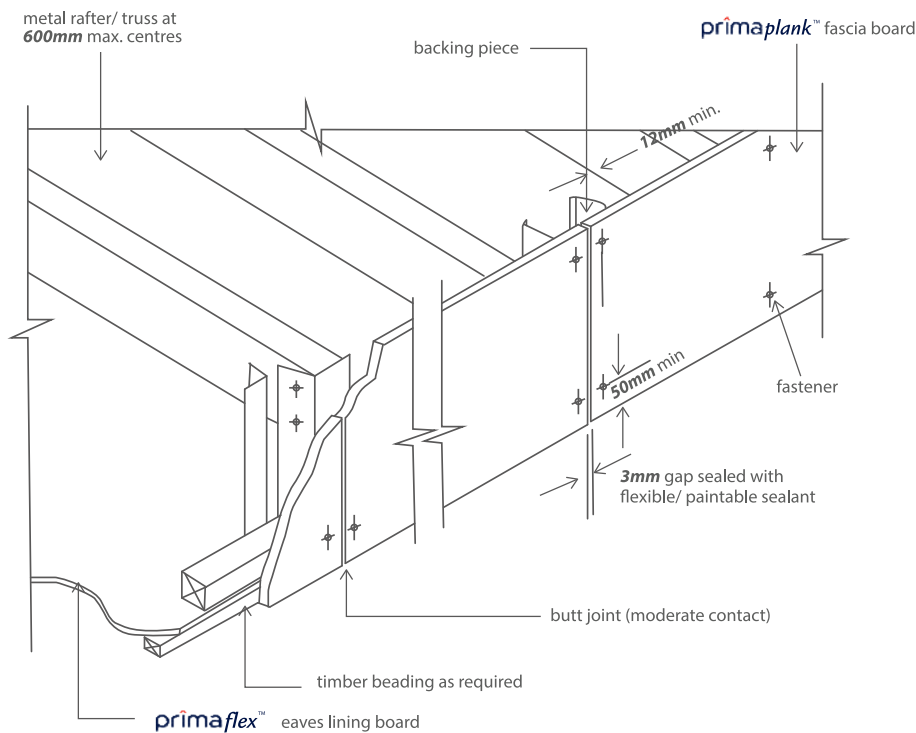

Figure 5.4: Butt joint & sealant (Metal rafter/ truss)

6 Decorative Fencing

6.1 General

primaplank™ can be incorporated in the construction of conventional *masonry*, *timber* or *steel* framed fencing for medium to high-end terrace houses as well as semi-D or bungalows.

6.2 Framing Requirement

Framing durability must satisfy the minimum requirement of the intended use. It is recommended to use *exterior grade (treated timber)* or *steel hollow section* to form the support. *Steel hollow section* must be suitably coated to resist external weather.

6.3 Installation

primaplank™ can be installed *vertically* or *horizontally*. In any case, support must be provided at **610mm centres maximum**. Install fasteners approximately **30mm** from edge and **50mm** from corner of plank. Fix at least **2 fasteners** at each support.

primaplank™ ends must not overhang (cantilever) more than 100mm from the support.

The following fasteners are suitable if it is desired to have screw heads exposed:-

- Timber Support: Use **No.10 x 30mm Hexagon head, Type 17** point screws
- Steel support: Use **No.10 x 28mm Hexagon head, self-drilling** point screws

Refer to screw *manufacturer's instruction* on the minimum screw penetration to framing member:

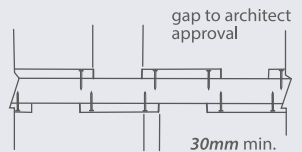

Horizontal Section

primaplank™ fencing applied vertically

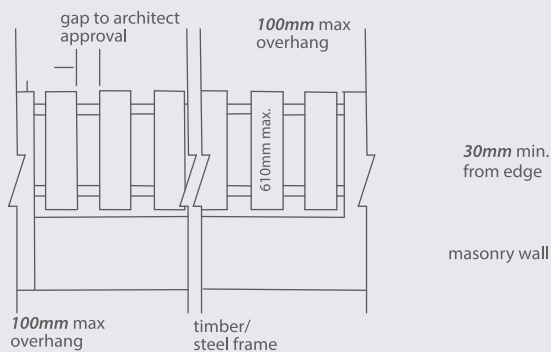

Front Elevation

Figure 6.3.1: Vertical fencing

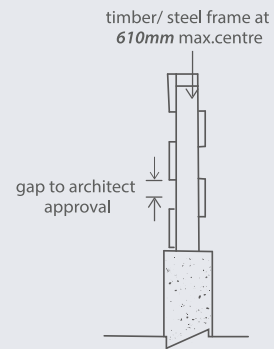

Horizontal Section

primaplank™ fencing applied horizontally

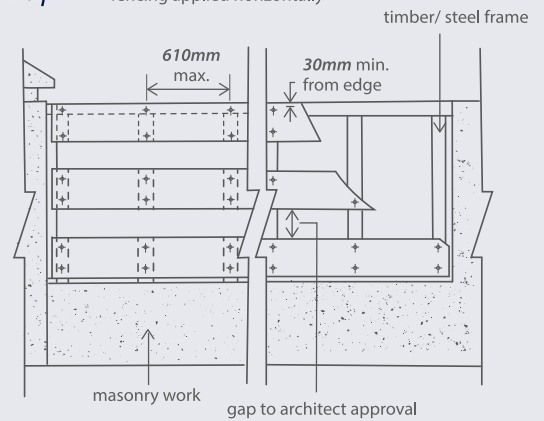

Front Elevation

Figure 6.3.2: Horizontal fencing

7 Ceiling and Eaves Lining

7.1 General

prima plank™ 9mm with 2 sided V-edge profile in 'Smooth' or 'Woodgrain' surface texture is always the preferred choice as alternative to the wood plank as the ceiling lining which provides the warmth and beauty of natural timber looking ceilings. It is not only durable but environmental friendly comparing by using traditional forest timbers.

7.2 Framing Requirement

Light gauge galvanized steel batten with standard size **36mm x 16mm x 0.42mm min. BMT** is used as the metal framing for ceiling joist. **prima plank™** must be supported at **407mm** maximum centres, refer Figure 7.2. Ensure the ceiling joists are reasonably flat and level prior the plank installation.

prima Ceiling System - Standard Duty

**Suitable for Internal ceiling*

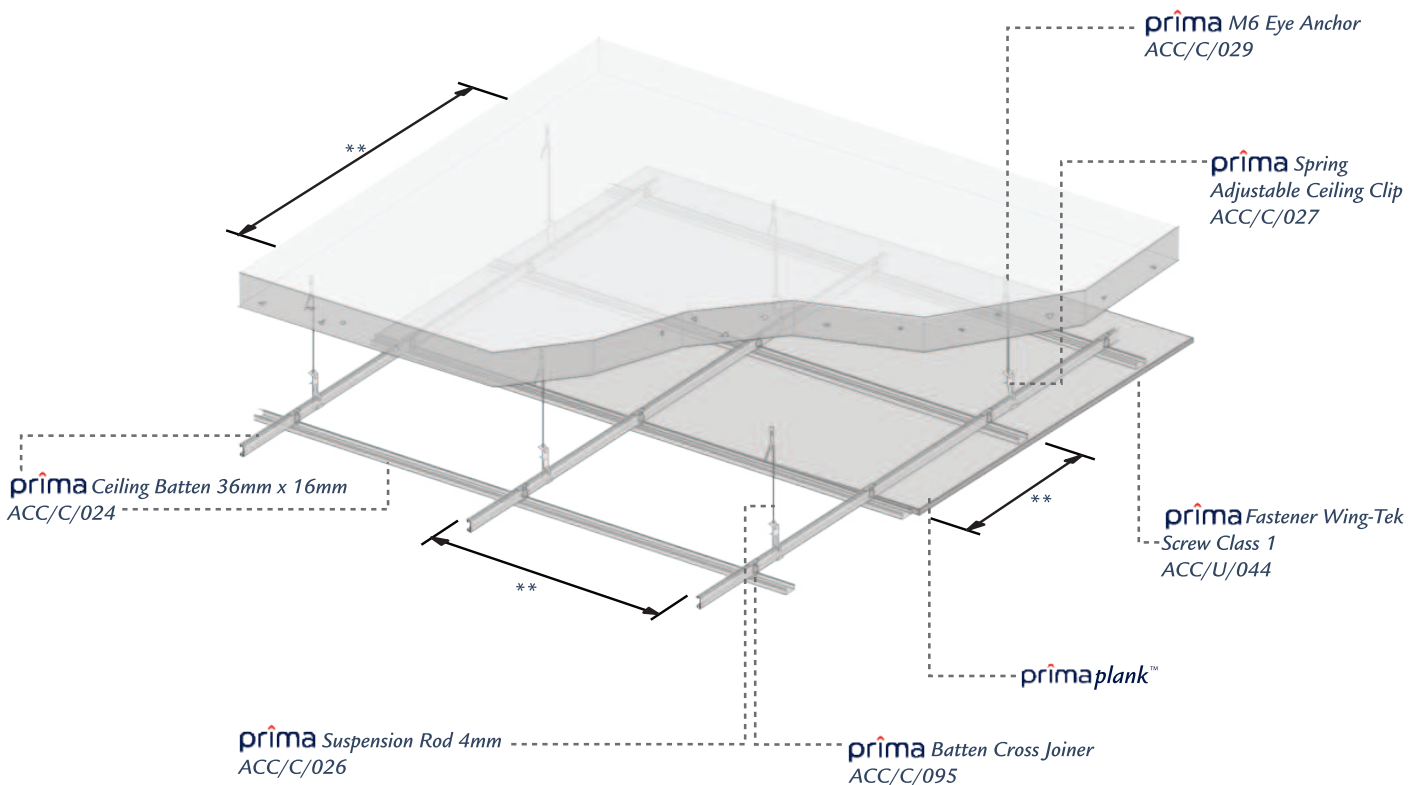

** Please refer to Saint-Gobain Prima Technical Team for actual frame spacing

Figure 7.2: Standard Duty Ceiling System

7.3 Installation

Install **prima plank™** 9mm across the ceiling joist in a staggered pattern. Fasten the plank onto ceiling joist by using the self-drilling self-embedding head wing tek screw (**prima Fastener Wing-Tek Screw Class 1 (28mm)**) with **407mm** fasteners spacing as shown in Figure 28. The screws are fastened at the centre of the plank. For plank width joint area, the screws are fastened 12mm minimum from the plank edge, refer Figure 7.3.1 Detail A. If the plank width edges fall at the off-stud jointing, a light gauge steel nogging is placed on top of the edge joints. Fasten the plank to the nogging accordingly.

All fastener heads must be covered with *Jointing Compound*. Clean dust out of holes to ensure adhesion of joint compound.

The **prima plank™** is generally installed with butt jointing plank ends with moderate contact as shown in Figure 7.3.2.

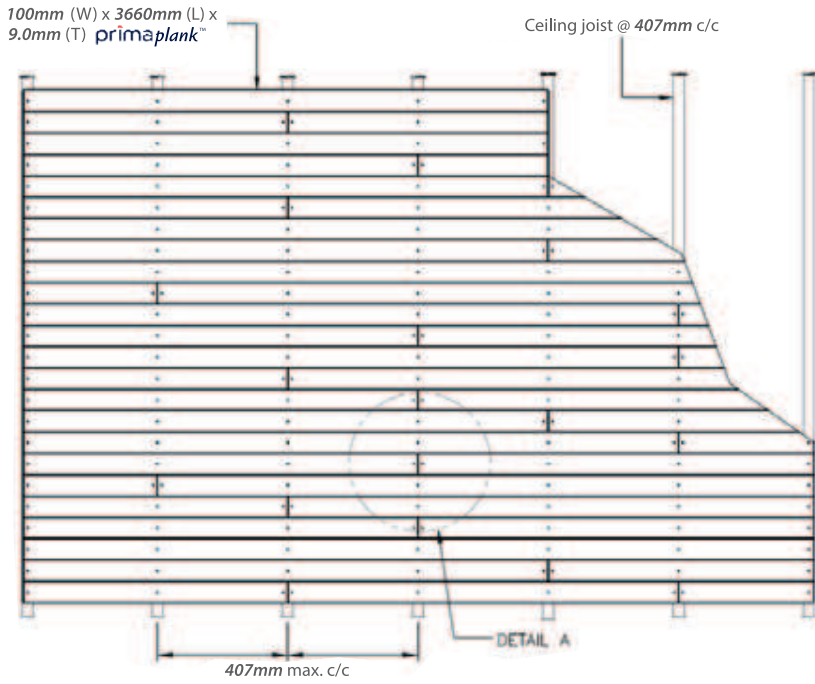

Figure 7.3.1: **primaplank™** ceiling installation

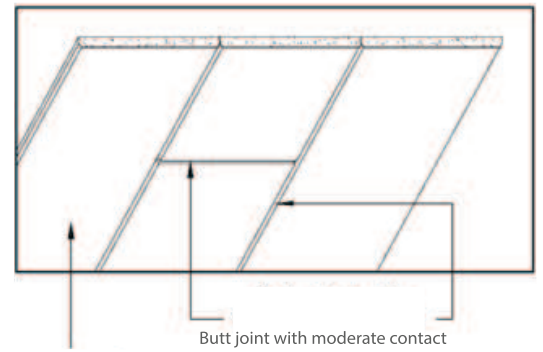
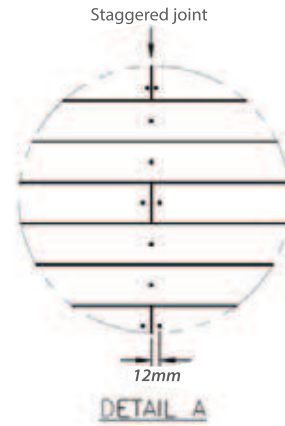
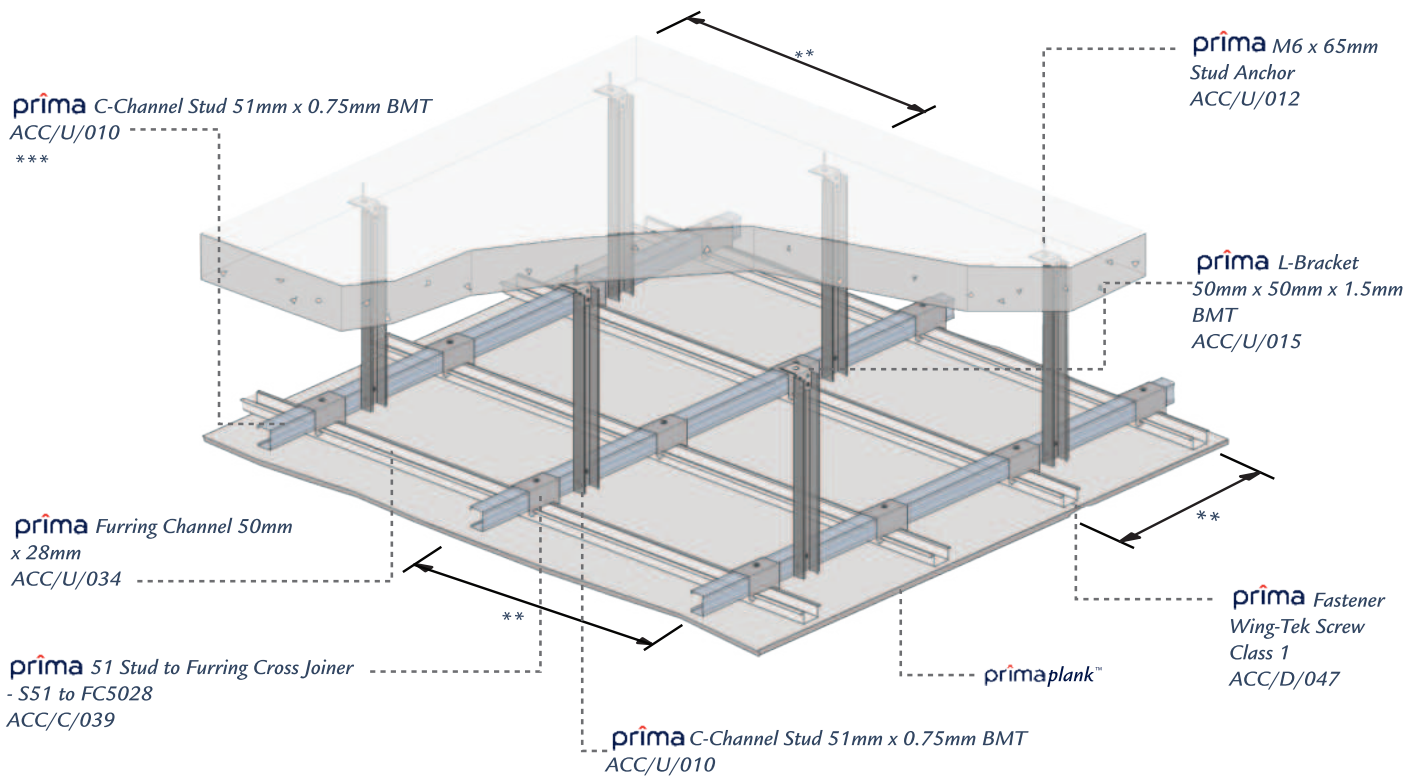

Figure 7.3.2: Joint Detail

prima Ceiling System - Heavy Duty

**Suitable for Internal and External ceiling
Can withstand wind pressure up to 1.5kPa



** Please refer to Saint-Gobain Prima Technical Team for actual frame spacing

*** Available in other sizes and specifications.

Figure 7.3.3: Heavy Duty Ceiling System

8 Decking / Flooring

8.1 General

primaplank™ Decking, offering choices of Smooth and Timbergrain textures and with light chamfer at length edges, is ideal for decking and flooring applications. It is the best substitution to natural timber decking for commercial and residential buildings and can be used for interior and exterior applications.

primaplank™ Decking can be applied on the steel frame.

8.2 Framing Requirement

The steel framing system is generally fabricated using light gauge galvanized steel C-section with BMT 0.75mm to 1.15mm BMT or

8.3 Installation

8.3.1 On Metal Framing

Ensure the framing system is designed and constructed in accordance with applicable building standards and acceptable building practices. Floor joists must be true and level. Lay **prima**plank™ decking in staggered position across the floor joist, refer Figure 8.3.1.

mild steel hollow section. It is the responsibility of structural engineer to ensure the framing system in which **prima**plank™ decking will be laid on will perform under the design load.

The decking or flooring joist or frame spacing shall be determined by loading requirements and comply with local building regulations. In all cases, the joist spacing must not exceed 400mm/407mm centres. Please refer to Saint-Gobain Prima Department for recommended joist spacing.

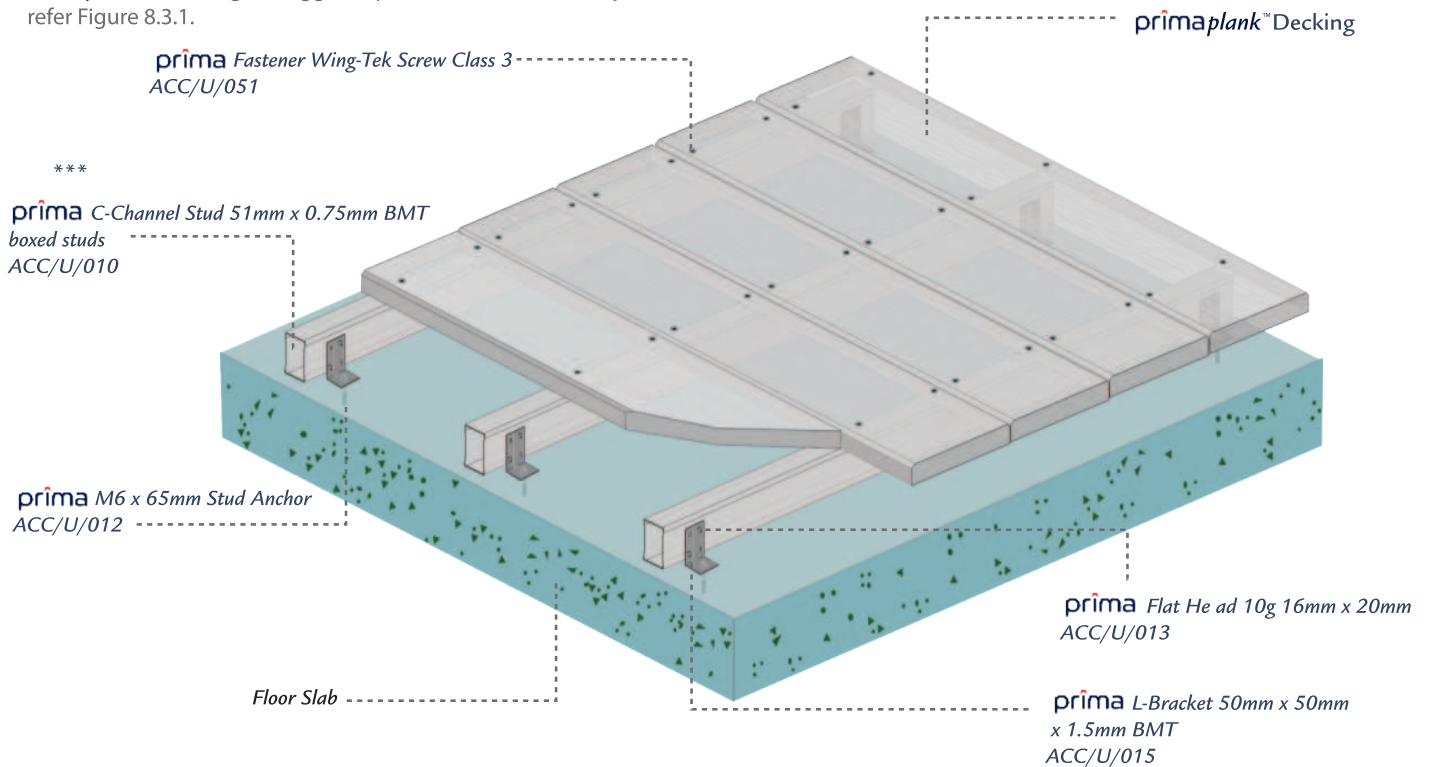

Figure 8.3.1: Typical Layout for **prima**plank™ decking onto Steel Frame

Use self-embedding head self-drilling wing tek screw to fasten the board to the frame according to Figure 8.3.1. Other fasteners can be used but might require pre-drilling. The fastener points to be covered with *Jointing Compound* or can be left un-covered which corrosion resistance at least Class 3 fasteners are required.

Sheets are normally butt joint at along edges and butt joint or expressed joint with 3 to 4mm gap at the cross edges, refer Figure 8.3.3 & 8.3.4. **For external application, please ensure all the surfaces (6 sides) of plank are coated with water proofing or sealers.**

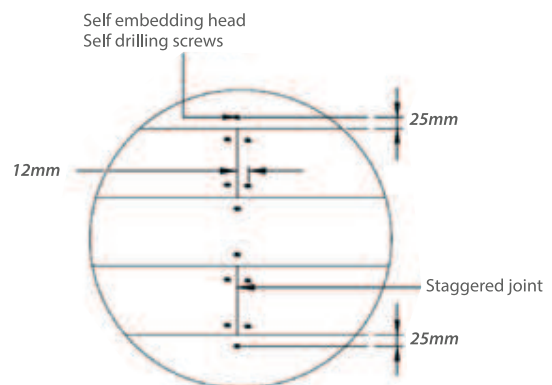

Figure 8.3.2: Fastener Fixing

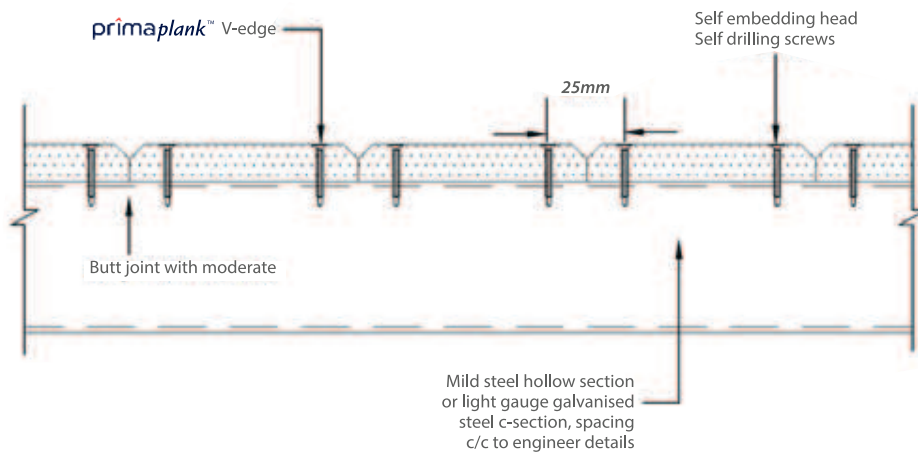

Figure 8.3.3: Joint Detail at along edges



Figure 8.3.4: Butt Joint and Express Joint at cross edges (width joint)

prima Decking Solution

1.1 prima Deck Concealed Fixing System (CFS)

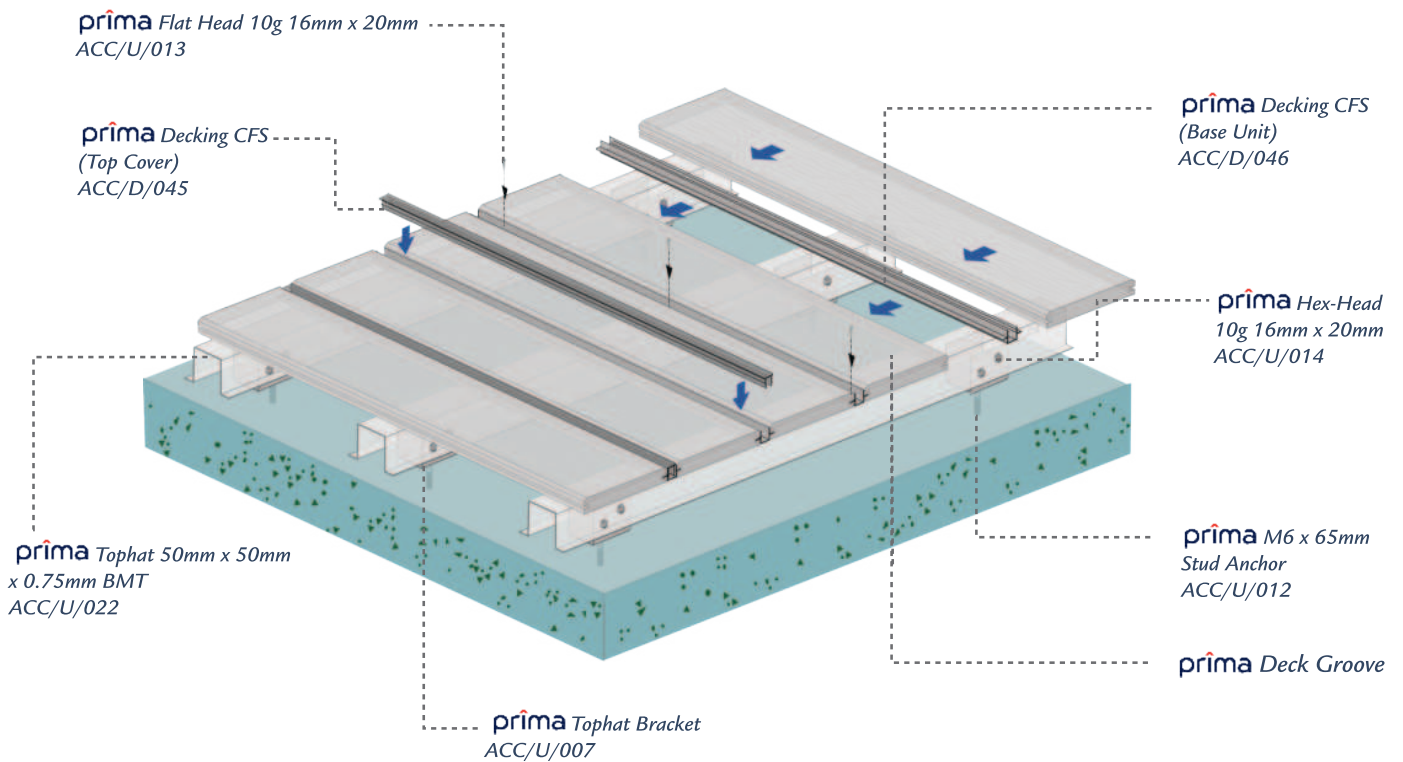

prima Decking Solution

1.2 prima Deck Groove (3mm Concealed Fixing Clip)

*with 3mm gap between 2 panels

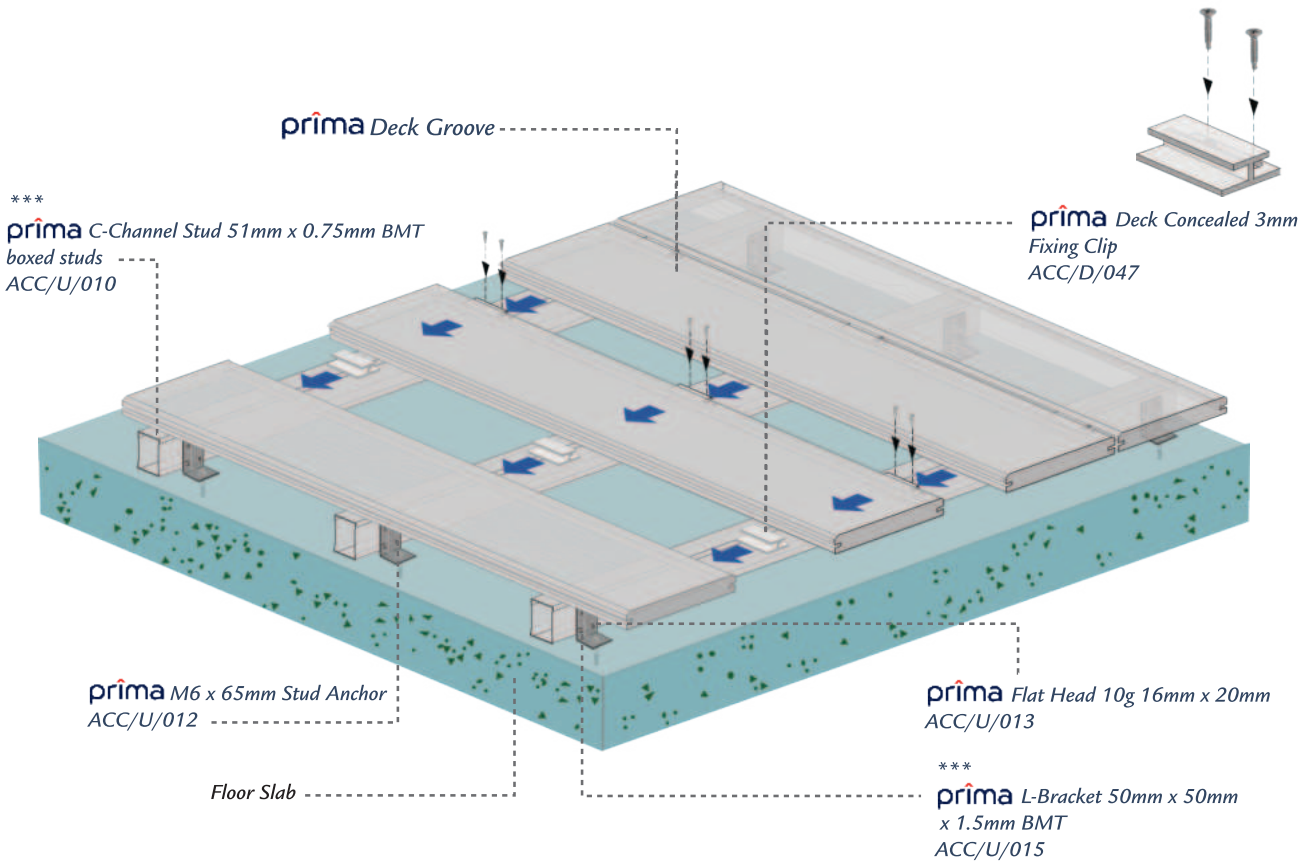

1.3 prima Deck Groove (10mm Concealed Fixing Clip)

*with 10mm gap between 2 panels

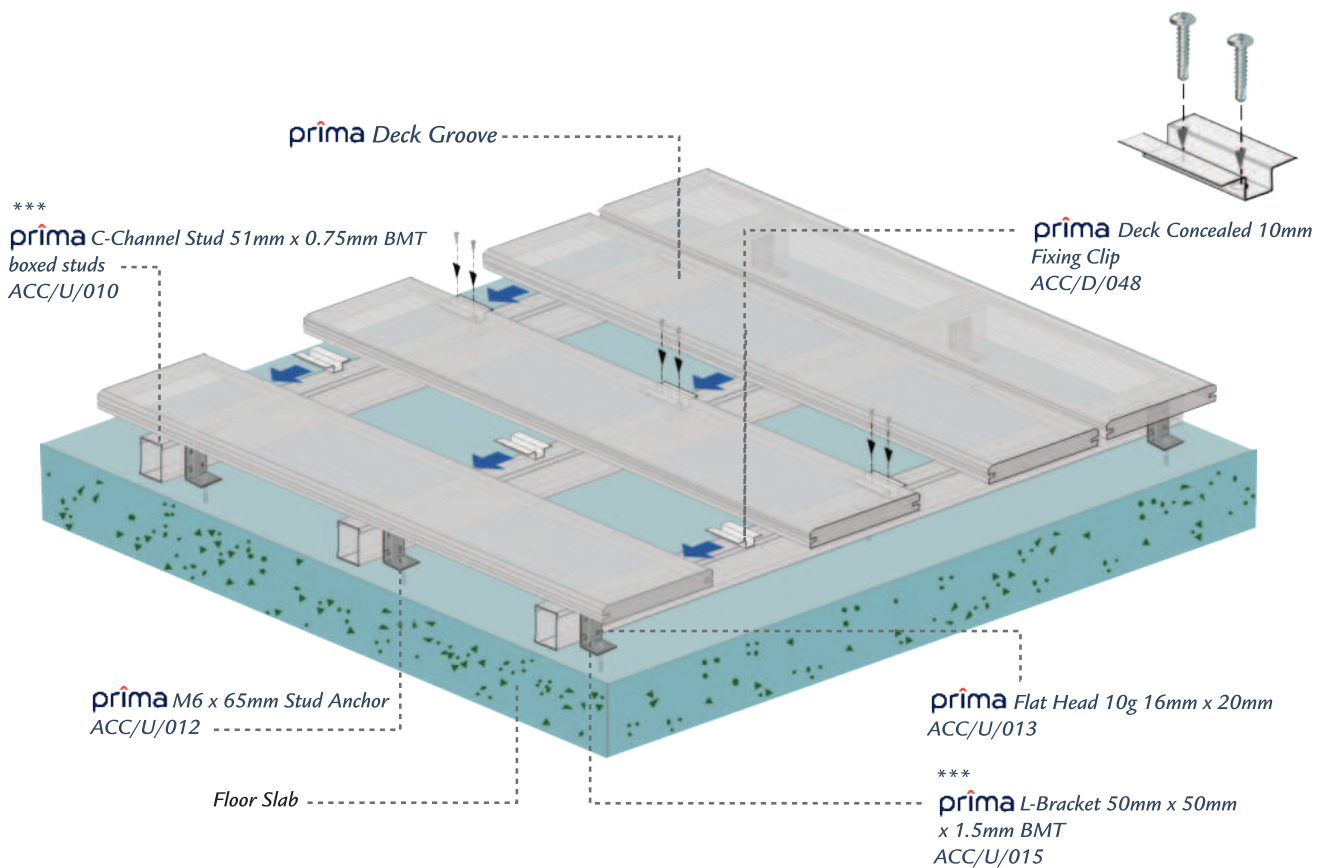

9 Finishes Recommendations

Under normal circumstances **primaplank™** must be coated as soon as possible after installation. For best result, decorate **primaplank™** with **2 coats of 100% quality acrylic paint**.

For general-purpose applications, there is no requirement for **primers** or **sealers**. Ensure planks are **dry prior to painting**.

For decorative fencing and decking application, plank must be coated on both surfaces and all edges. All plank exposed surfaces and edges must be painted.

For certain applications, it will be looked good by exposing the fastener head without any jointing compound.

In all cases, coating manufacturer's recommendations must be strictly adhered to.

10 Working Instructions

10.1 Cutting

Cutting must be carried out in a well-ventilated area using one of the following methods:-

• Score and Snap

Score the plank face with 'score and snap'. Repeat until depth reaches 1/3 of plank thickness. Snap plank upward to achieve clean break. Trim cut edge with rasp if necessary.

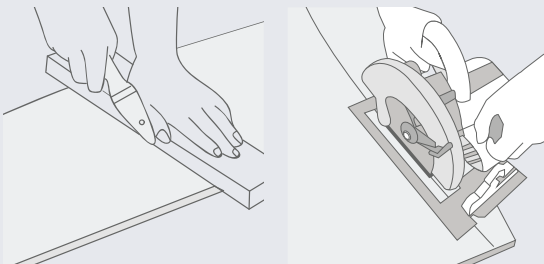

Figure 10.1: Score and Snap Method (left), Machine Cut (right)

• Hand Saw

The use of fine-toothed hand saw coupled with quick jabbing action will normally produces best result.

• Power Cutting Tool

When large amount of plank cutting is involved, use power cutting tool equipped with carbide-tip or diamond-tip circular saw.

10.2 Drilling

Small holes can be formed using high-speed (HSS) drill bits. Larger circular holes can be created by drilling a series of small holes around the perimeter of the proposed hole, and gently tapping out the waste piece. Smoothen the rough drilled edge with rasp if necessary.

10.3 Handling & Storage

primaplank™ must be stacked on flat ground and supported with level bearers prior to installation. Ensure all timber bearers of a stacked plank are aligned with other stacks. Improper plank stacking may result in permanent plank deformation that causes unsightly appearance such as waviness.

primaplank™ must always be kept dry, preferably stored under a protected shade. When stored outdoors, it must be protected from water ingress and weather by covering with tarpaulin sheet. Allow wet plank to dry to equilibrium under a natural ventilated condition prior to installation.

To minimize breakages, **primaplank™** must be carried with up-right.

prima™ accessories - List of Components

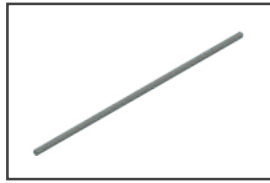

prima M6 Threaded Rod
ACC/U/001
Specifications : M6 Threaded Rod
Length 3000mm
Quantity : 50 pcs/box
Category : Ceiling
Application : Ceiling hanger / suspension

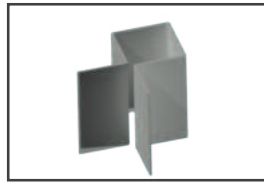

prima Corner Piece for Klassik
ACC/W/009
Specifications : 31mm x 31mm x 2440mm per pcs
Quantity : one piece
Category : Finishing trim for *primaplank® klassik*
Application : Walls & Cladding



prima M6 Push In Anchor
ACC/U/002
Specifications : M6 Push In Anchor
Quantity : 200 pcs/box
Category : Anchor
Application : Use as anchor to mount onto slab soffit. Ceiling hanger / suspension will be attach to it

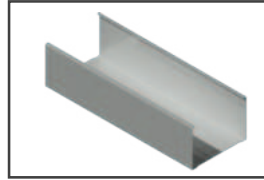

prima C-Channel Stud 51mm x 0.75mm BMT
ACC/U/010
Specifications : 51mm x 3000mm x 0.75mm BMT
Quantity : 100 pcs/pack
Category : Primary section
Application : Walls / Floors / Ceilings

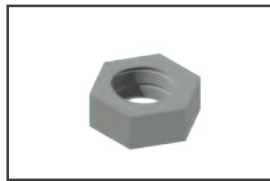

prima M6 Nut
ACC/U/003
Specifications : No #6 nut
Quantity : 1500 pcs/box
Category : Fastener
Application : Ceiling rod / hanger fasteners

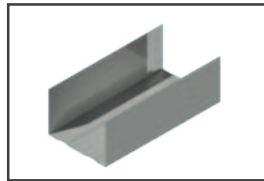

prima U-Channel Track 51mm x 0.75mm BMT
ACC/U/011
Specifications : 51mm x 3000mm x 0.75mm BMT
Quantity : 100 pcs/pack
Category : Primary section
Application : Walls / Floors / Ceilings

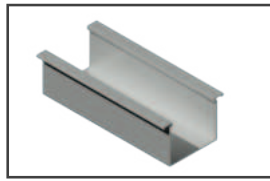

prima Furring Channel 38mm x 28mm x 0.50mm BMT
ACC/U/004
Specifications : 38mm x 28mm x 3660mm
Quantity : 200 pcs/pack
Category : Ceiling
Application : Ceiling secondary section

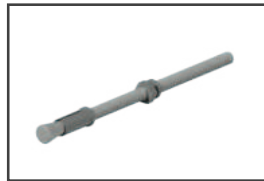

prima M6 x 65mm Stud Anchor
ACC/U/012
Specifications : M6 x 65mm Stud Anchor
Quantity : 250 pcs/box
Category : Anchor / Fastener
Application : Universal for floors / walls

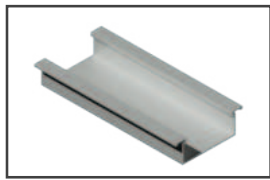

prima Furring Channel 38mm x 16mm x 0.50mm BMT
ACC/U/005
Specifications : 38mm x 28mm x 3660mm
Quantity : 200 pcs/pack
Category : Ceiling
Application : Ceiling secondary section



prima Flat Head 10g 16mm x 20mm
ACC/U/013
Specifications : No #10 x 20mm
Quantity : 1000 pcs/box
Category : Fastener
Application : To secure angle cleat on steel member

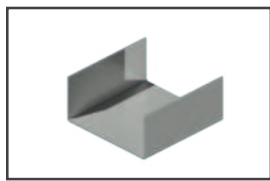

prima Furring Channel Joiner 38mm
ACC/U/006
Specifications : 38mm
Quantity : 400 pcs/box
Category : Ceiling
Application : Ceiling secondary section as connector / joiner



prima Hex-Head 10g 16mm x 20mm
ACC/U/014
Specifications : No #10 x 12mm
Quantity : 1000 pcs/box
Category : Fastener
Application : To secure angle cleat to steel member

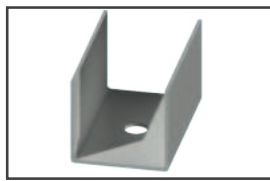

prima Tophat Bracket
ACC/U/007
Specifications : 80mm x 46mm x 50mm
Quantity : 60 pcs/box
Category : Floor joist / Cladding
Application : Secondary section connector to primary frame



prima L-Bracket 50mm x 50mm x 1.5mm BMT
ACC/U/015
Specifications : 50mm x 50mm x 1.5mm BMT
Quantity : 80 pcs/box
Category : Angle cleat
Application : Universal. To hold steel frame onto structure

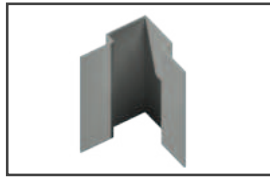

prima Corner Piece for Shiplap
ACC/W/008
Specifications : 31mm x 2440mm per pcs
Quantity : one piece
Category : Finishing trim for *primaplank® shiplap*
Application : Wall & Cladding



prima L-Bracket 75mm x 75mm x 1.5mm BMT
ACC/U/016
Specifications : 75mm x 75mm x 1.5mm BMT
Quantity : 40 pcs/box
Category : Angle cleat
Application : Universal. To hold steel frame onto structure

prima™ accessories - List of Components

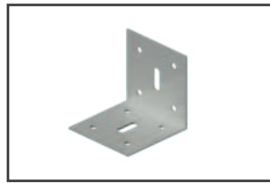

prima L-Bracket 55mm x 50mm x 1.9mm BMT
ACC/U/017
 Specifications : 55mm x 50mm x 1.9mm
 Quantity : 60 pcs/box
 Category : Angle cleat
 Application : Universal. To hold steel frame on structure

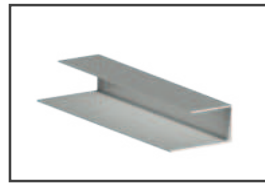

prima Furring Wall Track 16mm ACC/C/025
 Specifications : 16mm x 16mm
 Quantity : 120 pcs/pack
 Category : Trims
 Application : Ceiling

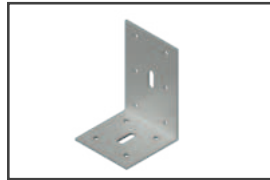

prima L-Bracket 75mm x 50mm x 1.9mm BMT
ACC/U/018
 Specifications : 75 mm x 50 mm x 1.9 mm
 Quantity : 50 pcs/box
 Category : Angle cleat
 Application : Universal. To hold steel frame on structure

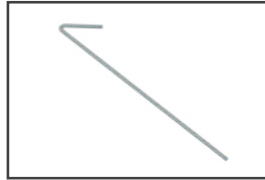

prima Suspension Rod 4mm ACC/C/026
 Specifications : 4mm diameter
 Quantity : 100 pcs/box
 Category : Suspension
 Application : Ceiling

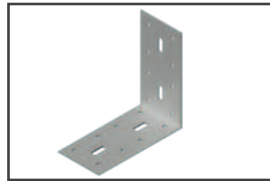

prima L-Bracket 100mm x 50mm x 1.9mm BMT
ACC/U/019
 Specifications : 100 mm x 50 mm x 1.9 mm
 Quantity : 30 pcs/box
 Category : Angle cleat
 Application : Universal. To hold steel frame on structure

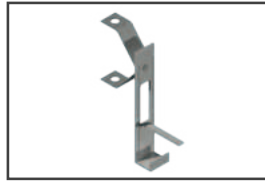

prima Spring Adjustable Ceiling Clip ACC/C/027
 Specifications : 132mm (L) x 22mm (W)
 Quantity : 180 pcs/box
 Category : Suspension clip / bracket
 Application : Ceiling

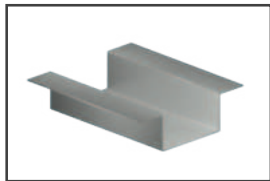

prima Tophat 25mm x 50mm x 0.75mm BMT
ACC/U/020
 Specifications : 25mm x 50mm x 0.75mm BMT
 Quantity : 120 pcs/pack
 Category : Secondary section
 Application : Universal / Floor joist, cladding

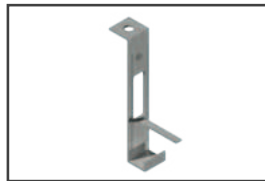

prima Threaded Adjustable Ceiling Clip ACC/C/028
 Specifications : 96mm (L) x 22mm (W)
 Quantity : 340 pcs/pack
 Category : Suspension clip/bracket
 Application : Ceiling

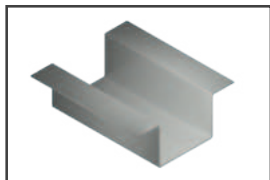

prima Tophat 35mm x 50mm x 0.75mm BMT
ACC/U/021
 Specifications : 35mm x 50mm x 0.75mm BMT
 Quantity : 120 pcs/pack
 Category : Secondary section
 Application : Universal / Floor joist, cladding



prima M6 Eye Anchor ACC/C/029
 Specifications : M6 x 60mm
 Quantity : 400 pcs/box
 Category : Anchor/ Fasteners
 Application : Ceiling

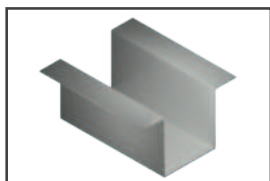

prima Tophat 50mm x 50mm x 0.75mm BMT
ACC/U/022
 Specifications : 50mm x 50mm x 0.75mm BMT
 Quantity : 120 pcs/pack
 Category : Secondary section
 Application : Universal / Floor joist, cladding

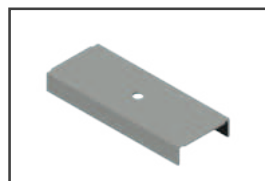

prima Batten Cross Joiner ACC/C/030
 Specifications : 100mm (L) x 35mm (W)
 Quantity : 480 pcs/box
 Category : Joiners
 Application : Ceiling

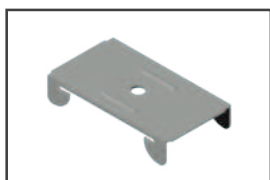

prima Direct Fixing Clip ACC/W/023
 Specifications : Direct fixing clip 36mm x 66mm
 Quantity : 50 pcs/box
 Category : Joiners
 Application : Wall, cladding



prima Direct Fixing Clips 175mm ACC/C/031
 Specifications : 190mm (L) x 76mm (W)
 Quantity : 200 pcs/box
 Category : Suspension clip / bracket
 Application : Ceiling



prima Ceiling Batten 36mm x 16mm ACC/C/024
 Specifications : 3600mm x 36mm x 16mm x 0.42mm BMT
 Quantity : 500 pcs/pack
 Category : Secondary section
 Application : Ceiling



prima Direct Fixing Clips 75mm ACC/C/032
 Specifications : 90mm (L) x 65mm (W)
 Quantity : 200 pcs/box
 Category : Suspension clip / bracket
 Application : Ceiling

prima™ accessories - List of Components

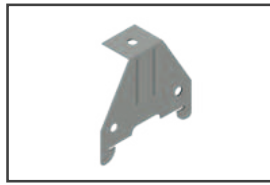

prima Flipped Direct Fixing Clips 75mm
ACC/U/033
Specifications : 68mm (L) x 65mm (W)
Quantity : 100 pcs/box
Category : Suspension clips/Brackets
Application : Universal / To secure steel elements at the right angle

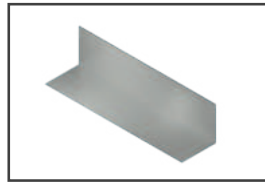

prima Angle 25mm x 25mm x 0.75mm BMT
ACC/U/041
Specifications : 25mm x 25mm x 3000mm
Quantity : 500 pcs/pack
Category : Angles
Application : Ceiling/Wall/Cladding

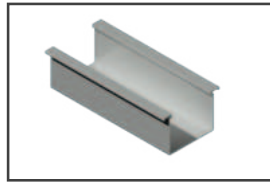

prima Furring Channel 50mm x 28mm
ACC/U/034
Specifications : 50 mm x 28 mm x 3600mm
Quantity : 200 pcs/pack
Category : Secondary section
Application : Ceiling

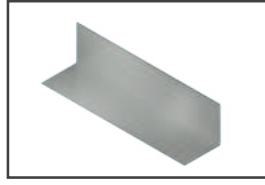

prima Angle 35mm x 35mm x 0.75mm BMT
ACC/U/042
Specifications : 35mm x 35mm x 3000mm
Quantity : 400 pcs/pack
Category : Angles
Application : Ceiling/Wall/Cladding

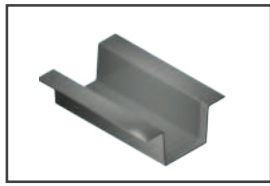

prima Hat Batten 38mm x 28mm x 0.50mm BMT
ACC/U/035
Specifications : 38 mm x 28 mm x 3600mm,
Quantity : 200 pcs/pack
Category : Secondary section
Application : Ceiling

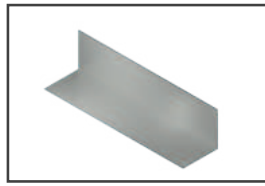

prima Angle 50mm x 50mm x 0.75mm BMT
ACC/U/043
Specifications : 50mm x 50mm x 3000mm
Quantity : 240 pcs/pack
Category : Angles
Application : Ceiling/Wall/Cladding

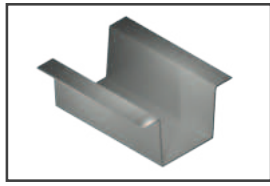

prima Hat Batten 50mm x 28mm x 0.50mm BMT
ACC/U/036
Specifications : 50mm x 28mm x 3600mm,
Quantity : 200 pcs/pack
Category : Secondary section
Application : Ceiling

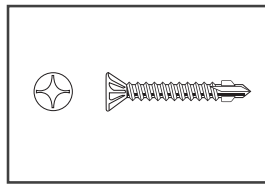

prima Fastener Wing-Tek Screw Class 1 (25mm/35mm)
ACC/U/044
Specifications : 25mm/35mm
Quantity : 1000 pcs/box
Category : Fasteners
Application : Wall/Cladding

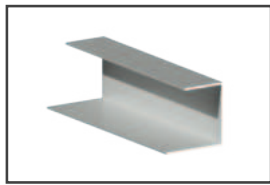

prima Furring Channel Wall Track 28mm
ACC/C/037
Specifications : 30mm x 28mm
Quantity : 120 pcs/pack
Category : Trims
Application : Ceiling

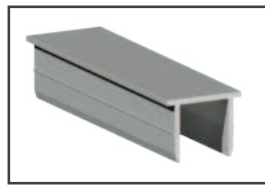

prima Decking CFS (Top Cover)
ACC/D/045
Specifications : Aluminium Powder Coated (Black)
Decking Strip Top-Cover
15mm (Gap), 3000mm (L)
Quantity : 20 pcs/box
Category : Strip Top Cover
Application : Decking

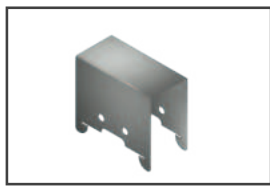

prima C-Channel Cross Joiner - S51 to FC3828
ACC/C/038
Specifications : 38mm x 76mm x 99mm
Quantity : 180 pcs/box
Category : Joiners
Application : Ceiling

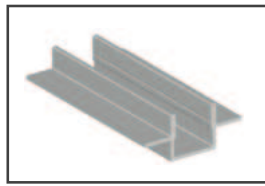

prima Decking CFS (Base Unit)
ACC/D/046
Specifications : Aluminium Powder Coated (Black)
Decking Strip Base-Unit
3000mm (L)
Quantity : 20 pcs/box
Category : Strip Base Unit
Application : Decking



prima 51mm Stud to Furring Cross Joiner - S51 to FC5028
ACC/C/039
Specifications : 38mm x 76mm x 99mm
Quantity : 120 pcs/box
Category : Joiners
Application : Ceiling



prima Deck Concealed 3mm Fixing Clip
ACC/D/047
Specifications : Conceal 3mm (Gap) Decking
Fix Clip, 3000mm (L)
Quantity : one piece
Category : Fasteners
Application : Decking

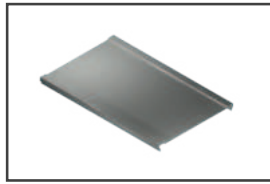

prima Furring Channel Joiner 50mm
ACC/C/040
Specifications : 61mm x 98mm
Quantity : 350 pcs/box
Category : Joiners
Application : Ceiling

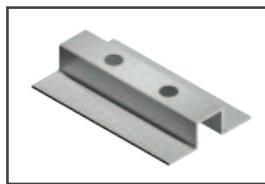

prima Deck Concealed 10mm Fixing Clip
ACC/D/048
Specifications : Conceal 10mm (Gap) Decking
Fix Clip, 3000mm (L)
Quantity : one piece
Category : Fasteners
Application : Decking

prima™ accessories - List of Components



prima Fastener Needle Point no#6 x 19mm
ACC/U/050
 Specifications : 19mm (L),
 Quantity : 1000 pcs/box
 Category : Fasteners
 Application : Ceiling

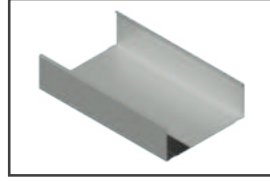

prima C-Studs 100mm x 0.55mm BMT
ACC/U/059
 Specifications : 100mm C-Studs x 0.55mm BMT
 (S10055), 100mm x 35mm x
 3000mm
 Quantity : one piece
 Category : Primary Section
 Application : Walls / Floors / Ceilings

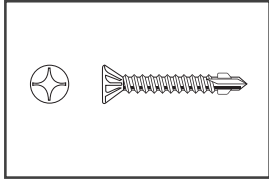

prima Fastener Wing-Tek Screw Class 3
ACC/U/051
 Specifications : 22mm/28mm/32mm/44mm,
 Quantity : 1000 pcs/box
 Category : Fasteners
 Application : Wall/Cladding

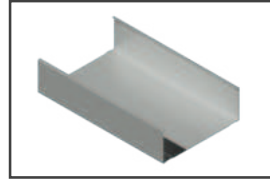

prima C-Studs 125mm x 0.55mm BMT
ACC/U/060
 Specifications : 125mm C-Studs x 0.55mm BMT
 (S12555), 125mm x 35mm x
 3000mm
 Quantity : one piece
 Category : Primary Section
 Application : Walls / Floors / Ceilings

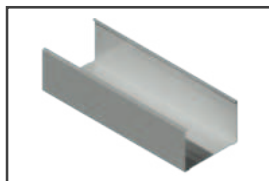

prima C-Studs 51mm x 0.50mm BMT
ACC/U/053
 Specifications : 51mm C-Studs x 0.50mm BMT
 (S5150), 51mm x 35mm x 3000mm
 Quantity : one piece
 Category : Primary Section
 Application : Walls / Floors / Ceilings

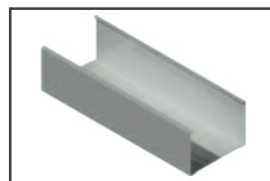

prima C-Studs 64mm x 0.75mm BMT
ACC/U/061
 Specifications : 64mm C-Studs x 0.75mm BMT
 (S6475), 64mm x 35mm x 3000mm
 Quantity : one piece
 Category : Primary Section
 Application : Walls / Floors / Ceilings

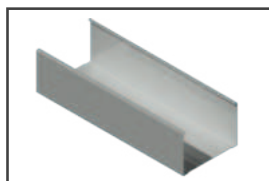

prima C-Studs 64mm x 0.50mm BMT
ACC/U/054
 Specifications : 64mm C-Studs x 0.50mm BMT
 (S6450), 64mm x 35mm x 3000mm
 Quantity : one piece
 Category : Primary Section
 Application : Walls / Floors / Ceilings

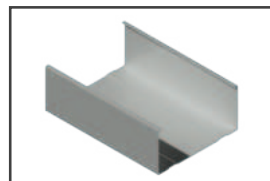

prima C-Studs 76mm x 0.75mm BMT
ACC/U/062
 Specifications : 76mm C-Studs x 0.75mm BMT
 (S7675), 76mm x 35mm x 3000mm
 Quantity : one piece
 Category : Primary Section
 Application : Walls / Floors / Ceilings

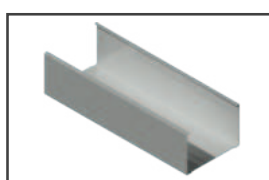

prima C-Studs 51mm x 0.55mm BMT
ACC/U/055
 Specifications : 51mm C-Studs x 0.55mm BMT
 (S5155), 51mm x 35mm x 3000mm
 Quantity : one piece
 Category : Primary Section
 Application : Walls / Floors / Ceilings

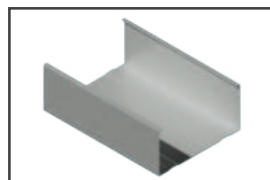

prima C-Studs 92mm x 0.75mm BMT
ACC/U/063
 Specifications : 92mm C-Studs x 0.75mm BMT
 (S9275), 92mm x 35mm x 3000mm
 Quantity : one piece
 Category : Primary Section
 Application : Walls / Floors / Ceilings

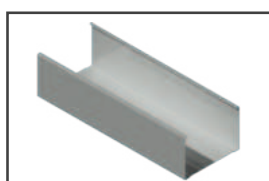

prima C-Studs 64mm x 0.55mm BMT
ACC/U/056
 Specifications : 64mm C-Studs x 0.55mm BMT
 (S6455), 64mm x 35mm x 3000mm
 Quantity : one piece
 Category : Primary Section
 Application : Walls / Floors / Ceilings

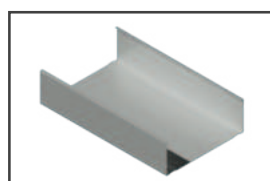

prima C-Studs 100mm x 0.75mm BMT
ACC/U/064
 Specifications : 100mm C-Studs x 0.75mm BMT
 (S10075), 100mm x 35mm x
 3000mm
 Quantity : one piece
 Category : Primary Section
 Application : Walls / Floors / Ceilings

Figure 8.3.1: Typical Layout for decking onto Steel Frame

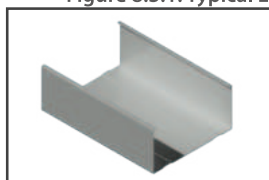

prima C-Studs 76mm x 0.55mm BMT
ACC/U/057
 Specifications : 76mm C-Studs x 0.55mm BMT
 (S7655), 76mm x 35mm x 3000mm
 Quantity : one piece
 Category : Primary Section
 Application : Walls / Floors / Ceilings

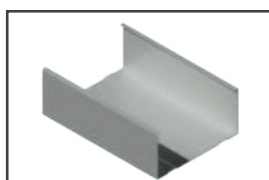

prima C-Studs 92mm x 0.55mm BMT
ACC/U/058
 Specifications : 92mm C-Studs x 0.55mm BMT
 (S9255), 92mm x 35mm x 3000mm
 Quantity : one piece
 Category : Primary Section
 Application : Walls / Floors / Ceilings

Remark :
 Please refer to the latest PRIMA Technical Manual prior to the installation.

prima™ accessories - List of Components

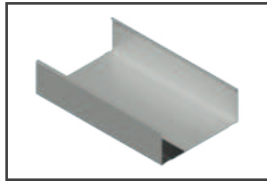

**prima C-Studs 125mm x 0.75mm BMT
ACC/U/065**
Specifications : 125mm C-Studs x 0.75mm BMT
(S12575), 125mm x 35mm x
3000mm
Quantity : one piece
Category : Primary Section
Application : Walls / Floors / Ceilings

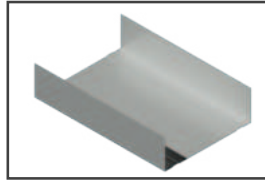

**prima U-Track 100mm x 0.55mm BMT
ACC/U/073**
Specifications : 100mm U-Track x 0.55 bmt
(T10055),
100mm x 32mm x 3000mm
Quantity : one piece
Category : Primary Section
Application : Walls / Floors / Ceilings

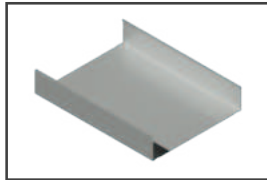

**prima C-Studs 150mm x 0.75mm BMT
ACC/U/066**
Specifications : 150mm C-Studs x 0.75mm BMT
(S15075), 150mm x 35mm x
3000mm
Quantity : one piece
Category : Primary Section
Application : Walls / Floors / Ceilings

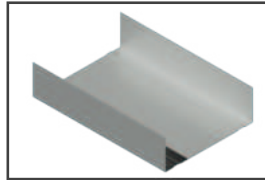

**prima U-Track 125mm x 0.55mm BMT
ACC/U/074**
Specifications : 125mm U-Track x 0.55 bmt
(T12555),
125mm x 32mm x 3000mm
Quantity : one piece
Category : Primary Section
Application : Walls / Floors / Ceilings

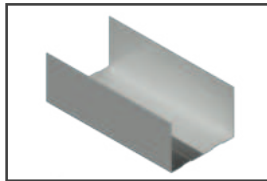

**prima U-Track 51mm x 0.50mm BMT
ACC/U/067**
Specifications : 51mm U-Track x 0.50 bmt (T5150),
51mm x 32mm x 3000mm
Quantity : one piece
Category : Primary Section
Application : Walls / Floors / Ceilings

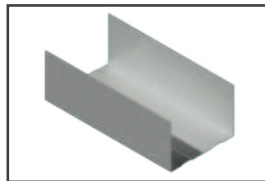

**prima U-Track 64mm x 0.75mm BMT
ACC/U/075**
Specifications : 64mm U-Track x 0.75 bmt (T6475),
64mm x 32mm x 3000mm
Quantity : one piece
Category : Primary Section
Application : Walls / Floors / Ceilings

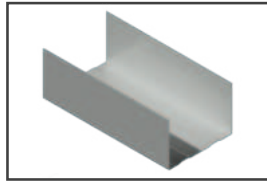

**prima U-Track 64mm x 0.50mm BMT
ACC/U/068**
Specifications : 64mm U-Track x 0.50 bmt (T6450),
64mm x 32mm x 3000mm
Quantity : one piece
Category : Primary Section
Application : Walls / Floors / Ceilings

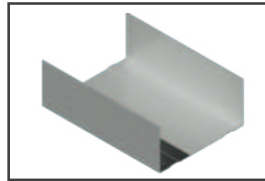

**prima U-Track 76mm x 0.75mm BMT
ACC/U/076**
Specifications : 76mm U-Track x 0.75 bmt (T7675),
76mm x 32mm x 3000mm
Quantity : one piece
Category : Primary Section
Application : Walls / Floors / Ceilings

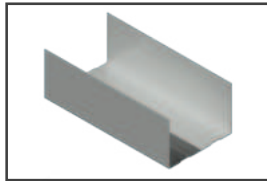

**prima U-Track 51mm x 0.55mm BMT
ACC/U/069**
Specifications : 51mm U-Track x 0.55 bmt (T5155),
51mm x 32mm x 3000mm
Quantity : one piece
Category : Primary Section
Application : Walls / Floors / Ceilings

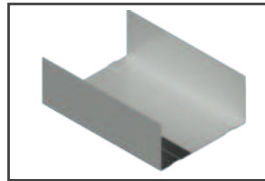

**prima U-Track 92mm x 0.75mm BMT
ACC/U/077**
Specifications : 92mm U-Track x 0.75 bmt (T9275),
92mm x 32mm x 3000mm
Quantity : one piece
Category : Primary Section
Application : Walls / Floors / Ceilings

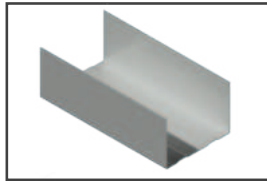

**prima U-Track 64mm x 0.55mm BMT
ACC/U/070**
Specifications : 64mm U-Track x 0.55 bmt (T6455),
64mm x 32mm x 3000mm
Quantity : one piece
Category : Primary Section
Application : Walls / Floors / Ceilings

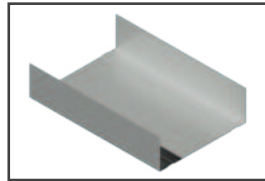

**prima U-Track 100mm x 0.75mm BMT
ACC/U/078**
Specifications : 100mm U-Track x 0.75 bmt
(T10075),
100mm x 32mm x 3000mm
Quantity : one piece
Category : Primary Section
Application : Walls / Floors / Ceilings

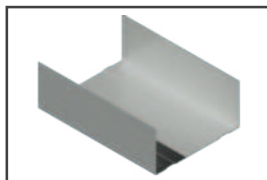

**prima U-Track 76mm x 0.55mm BMT
ACC/U/071**
Specifications : 76mm U-Track x 0.55 bmt (T7655),
76mm x 32mm x 3000mm
Quantity : one piece
Category : Primary Section
Application : Walls / Floors / Ceilings

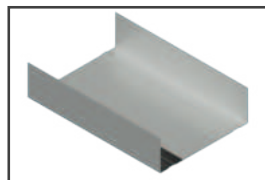

**prima U-Track 125mm x 0.75mm BMT
ACC/U/079**
Specifications : 125mm U-Track x 0.75 bmt
(T12575),
125mm x 32mm x 3000mm
Quantity : one piece
Category : Primary Section
Application : Walls / Floors / Ceilings

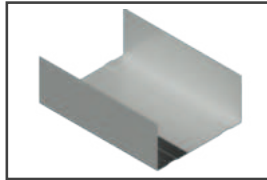

**prima U-Track 92mm x 0.55mm BMT
ACC/U/072**
Specifications : 92mm U-Track x 0.55 bmt (T9255),
92mm x 32mm x 3000mm
Quantity : one piece
Category : Primary Section
Application : Walls / Floors / Ceilings

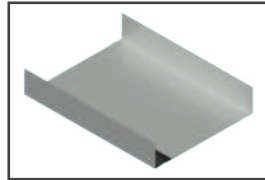

**prima U-Track 150mm x 0.75mm BMT
ACC/U/080**
Specifications : 150mm U-Track x 0.75 bmt
(T15075),
150mm x 32mm x 3000mm
Quantity : one piece
Category : Primary Section
Application : Walls / Floors / Ceilings

Remark :
Please refer to the latest PRIMA Technical Manual prior to the installation.

prima™ accessories - List of Components

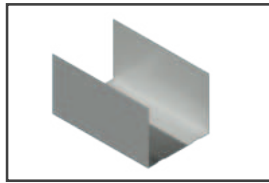

prima Deflection Head Track 51mm x 0.75mm BMT
ACC/U/081
 Specifications : 51mm Deflection Head Track x 0.75 bmt (D5175)
 51mm x 50mm x 3000mm
 Quantity : one piece
 Category : Primary Section
 Application : Walls / Floors / Ceilings

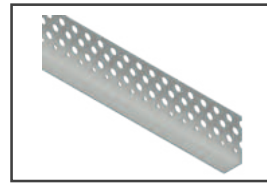

prima Stopping Angle 10mm x 30mm x 0.35mm BMT
ACC/C/089
 Specifications : 10mm x 30mm x 0.35mm BMT
 3000mm (L)
 Quantity : 500pcs/pack
 Category : Trim
 Application : Ceiling

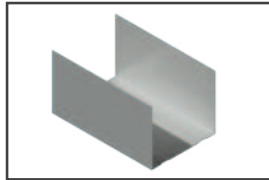

prima Deflection Head Track 64mm x 0.75mm BMT
ACC/U/082
 Specifications : 64mm Deflection Head Track x 0.75 bmt (D6475)
 64mm x 50mm x 3000mm
 Quantity : one piece
 Category : Primary Section
 Application : Walls / Floors / Ceilings

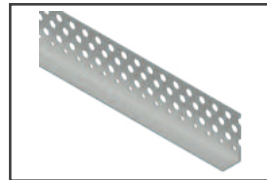

prima Stopping Angle 13mm x 30mm x 0.35mm BMT
ACC/C/090
 Specifications : 13mm x 30mm x 0.35mm BMT
 3000mm (L)
 Quantity : 500pcs/pack
 Category : Trim
 Application : Ceiling

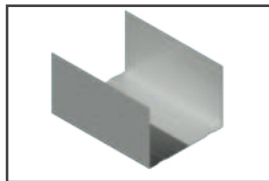

prima Deflection Head Track 76mm x 0.75mm BMT
ACC/U/083
 Specifications : 76mm Deflection Head Track x 0.75 bmt (D7675)
 76mm x 50mm x 3000mm
 Quantity : one piece
 Category : Primary Section
 Application : Walls / Floors / Ceilings

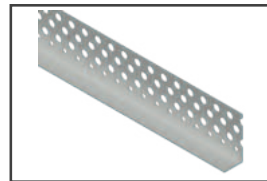

prima Stopping Angle 16mm x 30mm x 0.35mm BMT
ACC/C/091
 Specifications : 16mm x 30mm x 0.35mm BMT
 3000mm (L)
 Quantity : 500pcs/pack
 Category : Trim
 Application : Ceiling

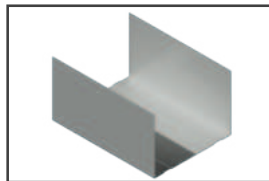

prima Deflection Head Track 92mm x 0.75mm BMT
ACC/U/084
 Specifications : 92mm Deflection Head Track x 0.75 bmt (D9275)
 92mm x 50mm x 3000mm
 Quantity : one piece
 Category : Primary Section
 Application : Walls / Floors / Ceilings

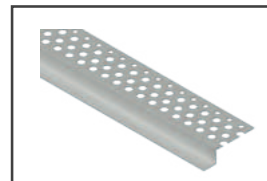

prima Shadowline 10mm x 10mm x 30mm x 0.35mm BMT
ACC/C/092
 Specifications : 10mm x 10mm x 30mm x 0.35mm BMT, 3000mm (L)
 Quantity : 500pcs/pack
 Category : Trim
 Application : Ceiling

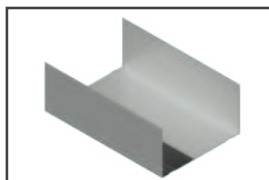

prima Deflection Head Track 100mm x 0.75mm BMT
ACC/U/085
 Specifications : 100mm Deflection Head Track x 0.75 bmt (D10075)
 100mm x 50mm x 3000mm
 Quantity : one piece
 Category : Primary Section
 Application : Walls / Floors / Ceilings

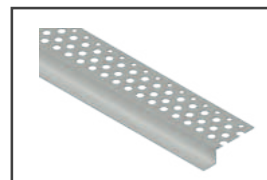

prima Shadowline 20mm x 10mm x 30mm x 0.35mm BMT
ACC/C/093
 Specifications : 20mm x 10mm x 30mm x 0.35mm BMT, 3000mm (L)
 Quantity : 500pcs/pack
 Category : Trim
 Application : Ceiling

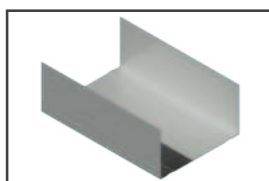

prima Deflection Head Track 125mm x 0.75mm BMT
ACC/U/086
 Specifications : 125mm Deflection Head Track x 0.75 bmt (D12575)
 125mm x 50mm x 3000mm
 Quantity : one piece
 Category : Primary Section
 Application : Walls / Floors / Ceilings

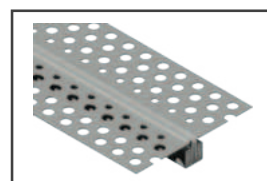

prima Control Joint
ACC/C/094
 Specifications : 0.35mm BMT flexible control joint
 3000mm (L)
 Quantity : 100pcs/pack
 Category : Trim
 Application : Ceiling/Wall

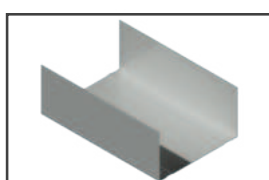

prima Deflection Head Track 150mm x 0.75mm BMT
ACC/U/087
 Specifications : 150mm Deflection Head Track x 0.75 bmt (D15075)
 150mm x 50mm x 3000mm
 Quantity : one piece
 Category : Primary Section
 Application : Walls / Floors / Ceilings



prima Ceiling Batten Cross Joiner
ACC/C/095
 Specifications : 40mm x 50mm
 Quantity : 500pcs/box
 Category : Joiners
 Application : Ceiling

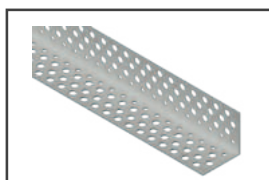

prima Corner Bead 30mm x 30mm x 0.35mm BMT
ACC/U/088
 Specifications : 30mm x 30mm x 0.35mm BMT
 3000mm (L)
 Quantity : 480pcs/pack
 Category : Trim
 Application : Wall/Cladding



For more information, please contact us at:



SAINT-GOBAIN PRIMA SDN BHD (579898-W)
 Level 19, Tower 5, Avenue 7 The Horizon,
 Bangsar South City, No. 8, Jalan Kerinchi,
 59200 Kuala Lumpur, Malaysia

General Line 1: +603 7781 1977 | General Line 2: +6012 781 1797

www.saint-gobain.my

[f](#) [t](#) [i](#) [v](#) [p](#) [s](#) saintgobainprima